



MINUTES
BOARD OF FIRE COMMISSIONERS
Regular Meeting
Tuesday April 14, 2026

ATTENDEES: Commissioner Marc Komorsky
Commissioner Vincent Tierney
Chief Anthony Champion
Deputy Chief Scott Merritt
Treasurer Mark Pozniak (via Teams)
Bookkeeper Jen Kaiser
Commissioner Robert Taft
Commissioner Jeff Kaiser
Deputy Chief Bryan Zittel
Attorney Michael Hekle (via Teams)
Secretary Bria Le
IT Consultant Jeff Lenkowski

At 6:05 PM, Chairman Komorsky called the Board of Fire Commissioners Regular Meeting to order for Tuesday April 14th, 2026, and led the Pledge of Allegiance. Chairman Komorsky thanked everyone for coming to the meeting.

MINUTES: - 3/24/26 Regular Meeting and 3/4/26 Special Meeting

Upon a MOTION made by Commissioner Tierney and SECONDED by Commissioner Taft, the Board RESOLVED to approve the 3/24/26 Regular Meeting minutes. Kaiser – Aye, Taft – Aye, Tierney – Aye, Komorsky - Aye. **Motion Carried.**

Upon a MOTION made by Commissioner Taft and SECONDED by Commissioner Tierney, the Board RESOLVED to approve the 3/4/26 Special Meeting minutes. Kaiser – Aye, Taft – Aye, Tierney – Aye, Komorsky - Aye. **Motion Carried.**

CORRESPONDENCE: -

- Check – There was a donation in the amount of \$75.00 from Vincent Liardo.
Upon a MOTION made by Commissioner Tierney and SECONDED by Commissioner Kaiser, the Board RESOLVED to deposit the \$75 check from Vincent Liardo into the General Fund. Kaiser – Aye, Taft – Aye, Tierney – Aye, Komorsky - Aye. **Motion Carried.**

Chairman Komorsky asked that a thank you card be sent to Mr. Liardo and Secretary Le stated she would send one.

- Checks – Two checks in the amounts of \$500 and \$600 respectively were received from NYS DOH for Paramedic and EMT Recertifications.
Upon a MOTION made by Commissioner Tierney and SECONDED by Commissioner Kaiser, the Board RESOLVED to deposit the \$500 and \$600 checks from NYS DOH into the General Fund. Kaiser – Aye, Taft – Aye, Tierney – Aye, Komorsky - Aye. **Motion Carried.**
- Check – A check in the amounts of \$25.00 was received from LexisNexis for a records request.
Upon a MOTION made by Commissioner Tierney and SECONDED by Commissioner Kaiser, the Board RESOLVED to deposit the check from LexisNexis in the amount of \$25.00 into the General Fund. Kaiser – Aye, Taft – Aye, Tierney – Aye, Komorsky - Aye. **Motion Carried.**

BoFC Regular Meeting 4/14/26

Please note that this meeting was conducted in person at 504 Freedom Plains Road in Poughkeepsie, NY AND open for public viewing and/or listening via Microsoft Teams.



LAGRANGE FIRE DISTRICT

504 Freedom Plains Rd • Poughkeepsie, NY 12603



ROOM USE REQUESTS:

- None.

OLD BUSINESS/UNRESOLVED ITEMS:

- Station 1 Building Update – Commissioner Tierney stated during the building inspection the staff that were attending discovered a number of issues. The EVR unit in the ready room is between 50 and 60 decibels, which is very loud and that is at the normal setting. On the high setting it is super loud. It tends to be very annoying. Another issue has to do with the bathrooms. When you are in the shower, the water runs onto the shower pan and then onto the floor and accumulates on either side and then makes its way into the hallway. That is unacceptable. Commissioner Kaiser stated there is a shower drain, which it doesn't go down, and there is also a floor drain for the bathroom, and the water misses that as well. It is with both bathrooms. The 4th item is that the IT room stays at an ambient temperature of whatever the whole complex is set at. If you set the complex at 72° the IT room is that temperature and the IT people are saying that the computer equipment needs to stay at 65°. Commissioner Kaiser asked if there was a thermometer in there now and Commissioner Tierney stated that it is on the equipment itself. Commissioner Kaiser asked if on a warmer day like today that room gets warmer than the 72°. Mr. Lenkowski stated he did not look at it today. Commissioner Kaiser asked how that room was going to stay at the same temperature as the rest of the building when there is no AC vented into that room. Commissioner Tierney stated there was an issue with one of the AC units. All of these issues were reported to CPL and Commissioner Tierney told them that staff could not move in while these issues were occurring. Chairman Komorsky stated they also need to be aware that this shoddy workmanship is costing the District more money with the cost of the two trailers and pumping and everything else to not have people back in the building. Commissioner Tierney stated those costs are approximately \$7000 a month. He stated at some point whether it is during a public meeting or an executive session with the attorney they will need to discuss what they want to do to move forward. Chairman Komorsky stated he believed that is an executive session discussion. Mr. Lenkowski had excused himself to go and check the temperature on the equipment and he reported back that it was at 84°. Commissioner Kaiser stated, for the record, if the building temperature is set for something the temperature in the IT room is going to be substantially higher. Once they get consecutive days of over 100° it's going to be trouble.
 - o Letter from Meyers - Commissioner Tierney stated that all of the packets included a copy of this letter. The letter stated that due to all of the delays including the asbestos and additional issues they are owed an additional \$45,900 for six months of additional coverage due to the extended time it took to complete this project. Commissioner Kaiser asked if this was part of the contract and Commissioner Tierney stated no it is because there were delays in getting the project completed. There is nothing in the contract that says there are additional funds required if the project is delayed. Chairman Komorsky stated this will be an executive session issue.
 - o Parking lots lights and pole – Chairman Komorsky stated there was a letter from O&D Electric Corp. regarding the parking lot lights on the north side of the building. When they were out there they had noticed that it was out. The pole is weakened. Chief Champion stated he did reach out to Central Hudson with no reply. They have had electricians look at it and they source it back to a dial control on the pole that is wobbly. It was discussed to put a ground box in and run it back to the main panel. He is waiting for a quote back from Giaimo and Black Electric's scope of work. He does not have those for this meeting

BoFC Regular Meeting 4/14/26

Please note that this meeting was conducted in person at 504 Freedom Plains Road in Poughkeepsie, NY AND open for public viewing and/or listening via Microsoft Teams.



LAGRANGE FIRE DISTRICT

504 Freedom Plains Rd • Poughkeepsie, NY 12603



but can share them once they are received. Chairman Komorsky suggested holding off on this issue right now until they get the additional quotes in. Commissioner Kaiser asked if it was a concern of the light pole. Chief Champion stated it was not. The telephone pole on the northeast corner of the building used to have the siren on it. It has an angle iron that connects it to the building but that is very loose in the soil. When the wind blows it shakes back and forth. It is a safety concern. The lights in the parking lot just don't work and that is a different safety concern. Commissioner Kaiser asked what the quotes for the photocell and time clock were for. Chief Champion stated when there is not enough ambient light, the photocell will automatically turn the lights on. That is for the five parking lot lights on the side. Those metal poles are intact and stable, but the lights don't turn on. The sensor is on the top of each unit so that unit will have to come off and be replaced with an updated LED and probably a photocell on each individual unit. The time clock he believes is to time how long they are on for. He can ask the electrician, but he is not back in until 7. He stated it was one of the conversations during one of the Friday meetings while the Station 1 work was going on. It was a side conversation because they saw the safety issue, so they engaged discussion with O&D Electric because they were on site and asked them for a price quote. He is still waiting for two more. Commissioner Kaiser asked what the safety concern was. Chief Champion stated there are no lights over there at night, so the entire side lot is completely dark. It could lead to transient people coming in and doing something nefarious and no one being able to see. Commissioner Kaiser asked if there was a cheaper way to repair it for an area that no one parks in. Chief Champion stated he does not have a cost to provide to the Board except for the aspect of Central Hudson owning and taking care of or updating them. He stated that Central Hudson owns the lights. Commissioner Kaiser stated he thought the district owned them. Chief Champion stated no, Central Hudson tags are on those lights. The District has paid for the electric over the years, but they have not paid it recently because there is no light on that side of the parking lot. Every one of those poles has a property of Central Hudson tag just like the telephone poles. Chief Champion reached out to them a few times and no one got back to him to send someone out. O&D came out and traced the wires and said the wiring is still OK, but they are not sure why the lights are not working. They were asked to put together a quote for repairs if the district chooses to take ownership of these lights and change them over to LED. They added in the wooden telephone pole on the northeast end of the building that held the old siren because it was wobbly. It does have a breaker box on it that runs power from the pole down the mast to that box that goes back out to these lights. Commissioner Kaiser stated that he does understand safety, but they don't use that parking lot anymore since there are no functions at that station. He asked if there could be a cheaper way to provide light out there without having to worry about those poles working. He asked if there was a way to put out some kind of a light to light up the side of the building that the cameras would pick up any motion in case somebody is out there without having to take over four parking lot lights for a parking lot no one uses. Commissioner Tierney stated the Conex boxes are back there. Chief Champion stated the plan was to make those boxes incorporated into some sort of training aspect for bailout windows for the staff at Station 1, so they do not have to come to Station 2 all the time. It could change. Commissioner Kaiser stated he is more concerned with the front of the firehouse and the blacktop issues than with a safety

BoFC Regular Meeting 4/14/26

Please note that this meeting was conducted in person at 504 Freedom Plains Road in Poughkeepsie, NY AND open for public viewing and/or listening via Microsoft Teams.



LAGRANGE FIRE DISTRICT

504 Freedom Plains Rd • Poughkeepsie, NY 12603



concern of lights in a parking lot that no one parks in. He thinks maybe they could get away with taking down the poles and putting up a few spotlights on the side of the firehouse. He still feels the wash away in the front of the firehouse is a bigger concern. Chief Champion stated he agrees with that concern. Commissioner Taft stated they could put lights on the side of the building and it should be cheaper. Chief Champion stated that would be fine as the District owns the building. He was asked to help out with this, so he reached out to three vendors for prices. He stated if the Board decides not to illuminate the side parking lot with those lights that is fine. There would still be some aspect of payment to remove everything that's there and deactivate it. Commissioner Kaiser stated he is just trying to save money. Chief Champion asked if they wanted to wait until the other two bids came back. Chairman Komorsky stated that seemed to be a good idea as this is not an emergency situation. While they are getting the other quotes he asked the Chief to also ask the electricians if there are any other alternatives that could cost less than doing it this way. Commissioner Kaiser stated he feels the Chief should be doing chief work and not contacting contractors to work on the district buildings. Chief Champion stated he will wait for the two quotes that he requested and then hand them off to the Board.

Commissioner Tierney asked Commissioner Taft if they were going to hold off on Phase 2 until after Friday's meeting between Commissioner Taft and a vendor.

Chief Champion stated per their request on Thursday Giaimo Electric will be in the kitchen taking out all of the dead wiring and sourcing the two live outlets back to the breaker panel. Commissioner Kaiser stated they need to wait because they had asked for two other quotes because they did not want to pay \$2800. They talked about the guy doing the kitchen possibly doing it cheaper when he is there to do the work on the kitchen. Chief Champion stated he has received conflicting reports and was told to move forward. He can cancel the vendor. Supposedly there is all dead wires hanging down and they are looking to get the guys back in the station as quickly as possible and to get the CO. He stated he is frustrated as there are multiple people coming to individual Board members on a singular basis getting stuff purchased to be put out there when they don't have an end date, when they have conversations that they are going to wait until they get the CO and have people moved in to then come up with a list to start purchasing things. Now stuff is sitting and waiting and may get lost and may get damaged. Commissioner Kaiser stated they had a deadline of May 15th a month ago and told the chief to order the beds and nightstands to get ready to move in. Some of this stuff was supposed to move forward back on the 15th of last month. Chief Champion stated that is fine and he is looking into that but there are other things that are going on with multiple conversations regarding purchasing items. He even had a conversation regarding how many beds we're supposed to be ordered. There is a conflict as to whether or not they need four beds or two beds and then someone said there might be three beds out there so there is no central list for anything getting ordered or being referenced to. He is completely frustrated. He has not ordered any new beds or mattresses to date because the date they were supposed to move in has come and gone and they still don't know when they are going to get in. He does understand that they asked for the beds and mattresses and nightstands to be ordered and those were all ordered and were delivered today. Commissioner Kaiser stated they did have a conversation about the beds and night stands a month and a half ago and they told him to order them. Chief

BoFC Regular Meeting 4/14/26

Please note that this meeting was conducted in person at 504 Freedom Plains Road in Poughkeepsie, NY AND open for public viewing and/or listening via Microsoft Teams.



LAGRANGE FIRE DISTRICT

504 Freedom Plains Rd • Poughkeepsie, NY 12603



Champion stated he did order them and his frustration comes from there not being a full list of what needs to be purchased. When the stuff is getting ordered it goes from a firefighter to upstairs, which is not the process. The process is that if a Union member wants something for the firehouse, they go to the House Committee. To his knowledge there are three members on the House Committee: Joe Kile, Rob Wells, and Sean Hatfield. The three of them are taking all of the information from the Union, putting it together, putting out lists to him and then they are moving it forward. The Union doesn't have purchasing power to buy stuff for the District out there, let alone a firefighter or a Lieutenant. If the captain decides he wants to start purchasing stuff for Station 1 in this regard then it will result in a conversation regarding his purchasing power because he is not using it for what it is intended. Most of the time anything that the Board wants to order results in a conversation in this setting and then it gets ordered. He does understand they had a conversation and the nightstands, lights, and hooks are ordered. There were TV's that were ordered that were unbelievable and are being returned. There is still no list. They had a conversation that they were going to move in first and then they were going to put a list together and then that list will be presented with a needs and a wants list and he has still yet to see that. He has the same people on the House committee that aren't even talking to each other. Commissioner Kaiser stated as far as he knows one of those members has not been out there at all. Two of the other members have been involved. He stated he is not disagreeing with the Chief on this, but they need to let the Union know. His problem is that they are spending \$2800 to pull wires out and he believes they all discussed that night that it was a lot of money to do that and maybe they should let the next guy who's going to rebuild the kitchen take it out. Commissioner Tierney stated he sent out an e-mail a while ago with 18 items on it and the 13th item was regarding furniture. It states, " House Committee/Chief need to nail down furniture dates." The second thing is the reason they asked to have the wires taken out is because after they went through there, they found an open box and they tripped over some wires and he stated they needed to get that taken care of before someone got injured in the hallway or kitchen. Commissioner Kaiser stated they could get a cover and put it on the box and Commissioner Tierney stated they could not because the box was hanging. If he wants to go to Page tomorrow and get the boxes and the wires and redo it, it's an option. Commissioner Kaiser stated he thought the conversation was that when they looked around there were no safety hazards as it was not an electrical safety hazard. It was just wires in the way. Chairman Komorsky stated he was told they did not know which wires were live and which wires were not. Commissioner Kaiser stated he had already looked at it and determined they were dead wires. Chairman Komorsky stated there appears to be an issue with transference of information. When it comes to wiring and electricity he does not want anyone to get shocked or to have it start a fire. Commissioner Kaiser stated they were dead wires and it was determined there was no safety hazard inside. They were just hanging in the way. Deputy Chief Zittel stated there are switches and wires that are live out there. If you go into the kitchen and try to turn the light switch on there is power to the switch but no cover on the wall. Yes there is a whole bunch of dead wires floating around but there are also a lot of live wires in the kitchen that need to be addressed. Chairman Komorsky stated to him that is an important issue that needs to be addressed. Commissioner Taft stated they could put covers on all the boxes and call it a day. Commissioner Tierney stated they will be bringing committee members in to

BoFC Regular Meeting 4/14/26

Please note that this meeting was conducted in person at 504 Freedom Plains Road in Poughkeepsie, NY AND open for public viewing and/or listening via Microsoft Teams.



LAGRANGE FIRE DISTRICT

504 Freedom Plains Rd • Poughkeepsie, NY 12603



look at the layout of the kitchen. Commissioner Kaiser stated he is just trying to save money. Commissioner Tierney stated it is foolish to save \$2800 to keep someone from getting cut or electrocuted. He stated they should spend the money and get it cleaned up. Commissioner Taft stated they should be moving pretty quickly on the kitchen with getting the design and getting the cabinets picked out. If they are getting estimates for the kitchen they might as well do that now. It might be a little cheaper if they waited for the guy doing the work. At that point it's just a matter of getting the cabinets. Commissioner Kaiser stated it is not just the cabinets. They have to put in a ceiling and put up sheetrock. They have to put a hood up there. There is a lot more than just hanging cabinets. It will be a couple of months. Chairman Komorsky stated it sounds like a safety issue to him. They asked how they could handle the safety issue at hand the best way. This is an issue they need to address right now. Commissioner Tierney stated he feels for \$2800 they should just get it cleaned up. Commissioner Kaiser stated he respects if the Chief believes that there is a hazard there. That is just not what they were told the last time. Chairman Komorsky asked what the Chief Staff thinks about this. Chief Champion stated if the Board would rather hold off then they are getting caps for boxes that are on the floor that are traced back to the breaker panel that could be dead. There are other lines that come into that area that he does not know where they go to. He is not an electrician. He can bring a meter in and tell you if it is dead or has a current going through it. A lot of the stuff that is hanging down is dead and a lot of it traces back to a dead box that is sitting in the old closet. The fact is that he does not know what is cross wired in this location and he knows that there are live outlets that are in that room that are in use for lighting. There is something running through the brick that he does not know where it connects to and some of it could be live. Commissioner Taft stated they are quoting \$2800 to go clean up some wires and Chief Champion said yes. Commissioner Kaiser stated his concern is that he was told it seemed like a lot of money to do that as they discussed holding off on it. He is not against cleaning up a hazard but there have been different things that have been talked about. Commissioner Tierney stated \$2800 is not a lot of money. Commissioner Taft stated \$2800 is a lot of money to him. Commissioner Tierney stated this is to cut back all of the wires, get rid of the hanging lights, get rid of the breaker box, and clean it up. Chief Champion stated they could just close the doors and not allow anybody in there. Commissioner Tierney stated the committee is going to come in when the vendor is here to discuss where they want the cabinets so they will need to be in there. Commissioner Taft suggested closing the doors and waiting for the rest of the estimates to come in for the kitchen and then take it from there. No one will be in there for a few weeks, and the cabinets aren't going to come in right away. Deputy Chief Zittel stated they can treat it like any other construction zone and anybody who enters into there must have the appropriate shoes and hard hats, just as they would at any other construction zone. That solves the immediate problem. You can still do your estimates and whatever, but you do it treating it like a construction zone. Chairman Komorsky stated his concern is that this is dealing with electrical stuff. That is why he's asking for input from everybody. Commissioner Taft stated at some point they will have to get an electrician in there. It would probably be better pricing at that point to have it done because he will already be in there. Commissioner Tierney stated only on the condition that the Board agrees that no member will go into that kitchen to check out the design we'll fit in there. Chairman Komorsky stated the Deputy

BoFC Regular Meeting 4/14/26

Please note that this meeting was conducted in person at 504 Freedom Plains Road in Poughkeepsie, NY AND open for public viewing and/or listening via Microsoft Teams.



LAGRANGE FIRE DISTRICT

504 Freedom Plains Rd • Poughkeepsie, NY 12603



Chiefs said it could be posted as a construction site and closed off. Commissioner Tierney stated that every time they make a decision one person is making the decisions instead of the group. He stated they're going to have people going in there with wires hanging down. Commissioner Taft stated you were going to have one contractor go in and ask the people involved what kind of kitchen they want and the vendor will go in and measure and come back and design a kitchen. Commissioner Tierney asked who was going to design the kitchen. Commissioner Taft stated he didn't feel it should be a ton of different people. He asked why they could not have one person from the house committee come in and bring back the suggestions to the other house committee members. Commissioner Tierney stated that they are very safety conscious, and he asked why they would send people in there with tape measures and rulers and walking around taking measurements with wires hanging down and light fixtures hanging down. Commissioner Taft stated it is crazier to spend \$2800 to go in there and make it safe for someone who's going to be in the room for a few minutes. Commissioner Kaiser said has been that way for six months. He stated they just need a measurement of the room. Commissioner Tierney stated that is not how it's going to work out. They are going to want to see it and measure it and bring a group of people in to give their opinions. Commissioner Taft stated that will not happen. They will close off the doors and the only people to go in there will be the commissioners. If they all want to go or one or two of them want to handle it, they will bring back all of the information to the other commissioners. Someone from the House Committee and the Chief Staff can review it and make the decisions. It has to be a collaborated decision. He just wants a functioning kitchen and doesn't want to pay \$1,000,000 for it. Commissioner Tierney stated that is why you need to bring people through and show them the area. Commissioner Taft asked how Commissioner Tierney got the drawings that he has and Commissioner Tierney stated everybody went through the room. Commissioner Taft asked how come it was OK to do that then and not now and Commissioner Tierney stated because it was not deconstructed at that point. Commissioner Kaiser stated his original point was that he did not know they were going to spend the money to do this and that there had been previous discussion about getting different prices because this seemed like a lot of money. Chairman Komorsky asked the chief staff if they can post on the doors that the room is closed off. Chief Champion stated he will send out a memo tonight stating that the doors are closed and no one is allowed in the kitchen. He will also inform the house committee they are not allowed in the room as well. Chairman Komorsky asked what their responsibility is if someone does go into that room after it is posted. Chief Champion stated they need to ask legal that as he cannot answer it. Chairman Komorsky asked Attorney Hekle, and he stated if the notice is clear and conspicuously identifies the potential dangers and it is sectioned off then it becomes a fact issue of what that person has claimed. They have done what they could. It needs to be clear and obvious to someone walking in the vicinity of the property.

- Station 2 Septic - Chairman Komorsky stated in everyone's packet there is an outlook page from MJ for the septic system and site work. There are a number of attachments. He asked if everyone had a chance to review this. One of the documents attached is a pay application for work completed through April 9th. The pay application includes work change directive #3 and directive #8, which address the replacement of soil in the new absorption bed. It requires signatures for approval as

BoFC Regular Meeting 4/14/26

Please note that this meeting was conducted in person at 504 Freedom Plains Road in Poughkeepsie, NY AND open for public viewing and/or listening via Microsoft Teams.



LAGRANGE FIRE DISTRICT

504 Freedom Plains Rd • Poughkeepsie, NY 12603



well. This work was completed based on a verbal approval. He stated hopefully everyone knew about that. They have also attached work change directives #5 for the Route 55 apron and entrance repair. Most of the Board, Chief Champion, and Deputy Chief Zittel should be familiar with this one. That work will be completed after authorized signatures are received. Directive #3 was discussed on April 8th, and it was a proposal to modify the design to the existing septic tank. There appears to be a drain line extending from the north part of the road running east across the parking lot and then ending at the bottom of the incline off to the South side of the property. For those members that were not here, Chief Champion and Deputy Chief Zittel were kind enough to have the duty crew take the tanker out and spray water on the roof to see where the water goes. That is how they found the drain. To avoid this roof drain they propose to use the existing 1500 gallon septic tank and move the dosing vaults out which are directly in front of the handicapped spot. The lateral into and out of the septic tank will be replaced and a clean out will be installed. They attached a drawing showing the new layout. There is no way to get the sewer lateral to an alternate septic tank location without putting several bends, which would require clean outs and possible maintenance issues. It would also cost a lot more. Replacing the tank in the current location would require the station to be without a sewer for several days. They asked if this was acceptable they could issue a work order change directive to JC Land to modify the layout and anticipate a credit for this work. Chairman Komorsky asked if anyone had any objections to items 1, 2 and 3. He would personally like to see this septic project done in the best way possible. Commissioner Kaiser asked if they were going to make a motion to replace the tank or leave it and Chairman Komorsky said leaving it there.

- o Work Change Directives 5 – 7

Chairman Komorsky read the directive #5 information and description for the Board. The contractor is to saw cut asphalt apron at the east entrance and then transport and spread 2 trucks of item 4 at top entrance to level out the settled area between the training area and the asphalt apron for a cost of \$3500.

Upon a MOTION made by Commissioner Tierney and SECONDED by Commissioner Kaiser, the Board RESOLVED to approve work change directive #5 fixing the entrance and exit out onto Route 55 in the amount of \$3500. Kaiser – Aye, Taft – Aye, Tierney – Aye, Komorsky – Aye. **Motion Carried.**

Chairman Komorsky read work change directive #6 to install an extra 150 feet of two inch conduit, two 75- foot long runs plus one round box. Round box to be installed in general area of pump station. The purpose of the work directive is that the district would like conduit installed to accommodate future electrical service. That is for a cost of \$1000.

Upon a MOTION made by Commissioner Taft and SECONDED by Commissioner Tierney, the Board RESOLVED to approve work change directive #6 for running the additional conduit in the amount of \$1000. Kaiser – Aye, Taft – Aye, Tierney – Aye, Komorsky – Aye. **Motion Carried.**

Chairman Komorsky read work change directive #7 to have the contractor replace three 6-foot white pines with three 6-foot blue point junipers with the relocation of the trees as shown on the plans. Commissioner Kaiser stated he thought they were taking this out of the plans and Chairman Komorsky stated that is what he remembered as well. He did want it to be mentioned during public session. Commissioner Kaiser stated this is a price increase due to the trees, but he asked if Chairman Komorsky got a cost savings if this was removed completely Chairman Komorsky stated he did not get that information. The

BoFC Regular Meeting 4/14/26

Please note that this meeting was conducted in person at 504 Freedom Plains Road in Poughkeepsie, NY AND open for public viewing and/or listening via Microsoft Teams.



LAGRANGE FIRE DISTRICT

504 Freedom Plains Rd • Poughkeepsie, NY 12603



original plan was for them to do it themselves. It is nowhere near the septic. Commissioner Kaiser stated the vendor is doing a great job but had mentioned that the trees are a lot more money. He stated the Board thought they could save some funds if this item was done in house.

Upon a MOTION made by Commissioner Taft and SECONDED by Commissioner Kaiser, the Board RESOLVED to remove work change directive #7 for changing out the trees in the amount of \$1000. Kaiser – Aye, Taft – Aye, Tierney – Aye, Komorsky – Aye. **Motion Carried.**

Chairman Komorsky asked Secretary Le to please send an e-mail to the contractor letting them know that item 7 is to be removed. She should also ask what the savings for this removal will be. Commissioner Kaiser stated the \$600.00 was for changing the trees to the blue point pines. He would like to know the total cost savings for removing any type of tree. Chairman Komorsky stated they need to know the credit for removing any trees from the quote. Chief Champion asked when the item 4 for the Conex was going to be complete in regard to this project. They do have training coming up at the end of this month and beginning of next month. Parking is already limited. If it is done and completed they can probably get 8 to 10 more parking spots opened up. Chairman Komorsky stated he did ask that and he was told they are working as quickly as they can. Commissioner Kaiser stated there is a partial pad already there and he asked why could they not just use that. Deputy Chief Zittel stated they missed the opportunity to move the Conex box. Chief Champion stated one of the boxes has items in it that have been left for donation. He asked when that was going to be done because there are plans to utilize that area. Inside are compressors, tires, switches, and components for the compressor. Chief Champion stated he does not want to do the training and work in there with that stuff there because he does not want it to get damaged nor does he want it to fall and hurt someone. Chairman Komorsky stated he would work on trying to get it all removed. It is not something he can do himself. He does have someone who is interested in it so he will call them and tell them if they want it they need to come and get it. Deputy Chief Zittel stated if they are here with equipment getting ready for that class, he can have the stuff moved someplace. Chairman Komorsky stated he believes the person that wants it will have the ability to take it out. He will get in touch with that person tomorrow.

Commissioner Kaiser asked for clarification that they are not putting the new septic tank in but are going to use the old septic tank and run it out from there. They're going to replace the line from the building out to the tank and then run that line from the old tank out.

Upon a MOTION made by Commissioner Kaiser and SECONDED by Commissioner Tierney, the Board RESOLVED to have the contractor use the existing old septic tank and run whatever lines they need to. Kaiser – Aye, Taft – Aye, Tierney – Aye, Komorsky – Aye. **Motion Carried.**

Chairman Komorsky stated he will sign whatever paperwork needs to be done so it can be sent out in the morning. Commissioner Kaiser stated just to clarify that if it's going to take 2 days to get this done they may need to get a second porta potty because the crews will not be able to shower for two days. Commissioner Tierney stated he heard that the perk test failed.

Chairman Komorsky stated he did not hear that. He asked if Chief Champion had heard that. Commissioner Kaiser stated he was here and the gentleman said it did not pass. Chief

BoFC Regular Meeting 4/14/26

Please note that this meeting was conducted in person at 504 Freedom Plains Road in Poughkeepsie, NY AND open for public viewing and/or listening via Microsoft Teams.



LAGRANGE FIRE DISTRICT

504 Freedom Plains Rd • Poughkeepsie, NY 12603



Champion stated he has observed an individual from MJ over the course of the last two weeks at least twice perk testing the ground. Today he was here and stated that the initial test that he was running looked good and everything was in the appropriate time frames. He stated he was going to communicate that officially to Denise who would get it back to the Board members. Commissioner Kaiser stated he was disappointed because it seems like the company is not coming in with the proper equipment to pack the septic tank down and to pack the road down. The Chairman stated that during this process they have learned that not all bids are created equal. Taking a low bid is not necessarily the best plan because sometimes you get exactly what you pay for. The low bid is not always necessarily the best bid. He does believe they can learn from this moving forward. Chief Champion stated they did come through with a hand tamper to tamp it all down. They did some tests that did not work out. They went back. He does believe at that point they contacted the Department of Health and the DOH gave them additional directions. They came back with a remote control roller that had vibrating capacity and they were out there compacting it a bit more. Commissioner Kaiser stated it should have been taken care of correctly the first time. That is how you should do a job. Chief Champion stated that he does not want to steal Treasurer Pozniak's thunder especially since he is not here tonight but he and the Deputy Chief and Treasurer Pozniak sat in with the auditors last week. There were a few things that came out of it that he will bring forward to the Board. One of the things the chief would like to share is that they suggested that potentially the Board can adjust their policy for bids. They can put something into the bid spec referencing best value and having quality bid aspects to measure against. That way they do not have to choose the lowest bid because best value is not a measurable characteristic that they put in their reply. He will let Treasurer Pozniak delve more into that next time. Chief Champion does implore the Board to think about that topic in regard to their purchasing policies to maybe get away from areas and instances that they are describing. Commissioner Kaiser stated they are great people and they are doing a great job. When it comes down to the small details they don't seem to be there. Chairman Komorsky asked if there were any other questions about the septic system project.

- Station 2 Emergency Generator Assessment – Chairman Komorsky stated Anthony from Caterpillar was out here a week or so ago. They were looking at the location of the boxes. They are moving forward with that and waiting for them to come back with a quote for the generator. It has been some time since they were told to bring back a photo and model number and everything else needed. All of the spec work is basically done between MJ and the sub. Once they get all that they will make sure everyone else has it as soon as possible. It is a work in progress, but they are getting close to being done with it. Secretary Le stated there should be an invoice in with the bills to be signed. She believes it is an invoice for the work that has already been done. Chairman Komorsky stated they're getting close to the whole thing basically being completed. Chief Champion stated there is a MIG Grant out there right now that the generator could fall into the infrastructural aspect that they could potentially submit for. There is also an infrastructural aspect of security. If they have a cost for the generator they can take that cost and submit it through the MIG Grant Program through Dutchess County. They also have Blue Dragon working on quotes to upgrade the cameras around the exterior of the building to see if that could also fall into something they can get additional grants for. He asked if there was any way they could usher forward a cost associated with the generator so they can provide that information to the grant. Chairman Komorsky stated he can get the

BoFC Regular Meeting 4/14/26

Please note that this meeting was conducted in person at 504 Freedom Plains Road in Poughkeepsie, NY AND open for public viewing and/or listening via Microsoft Teams.



LAGRANGE FIRE DISTRICT

504 Freedom Plains Rd • Poughkeepsie, NY 12603



generator costs for them if they would like. Chief Champion stated the deadline for that grant submission is May 13th. He stated since they are on grants, it was discussed that one of the legal councils that is being retained by the district would like access to the County's MIG Grant program website. He asked which legal counsel on retainer is getting that information. Chairman Komorsky stated it is Brown and Weinraub. Chief Champion stated he is in the process of setting up an access just for them so he will get that to them by the end of the week.

- Station 2 Brick Repair – Commissioner Tierney stated they have kind of tied the brick repair and roof repair together. The roof vendor came out, and he needs the bricks smoothed over so he can provide an estimate. The brickwork up there right now is not level. They need to do the flashing as well. Commissioner Kaiser asked when the mason was coming back and Commissioner Tierney stated he does not know. He will probably have to take some levels off and build it up with concrete.
- Station 3 IT Room Repairs – Chief Champion stated the room off of the ready room at Station 3 has been completed. The HVAC has been reinstalled on the wall and Jeff is aware of this. He will coordinate getting everything relocated from the ready room back into the secured space. Once that is done he will let everyone know.
- Staffing Community Events – Chief Champion stated at this time the community event that is on the calendar is the June 24th through 27th Knights of Columbus carnival. At a minimum he would like to send the ambulance. He has yet to send out notification to any membership for availability to stand by at this event. He is hoping to get that done before the end of the month. They received a request to attend the annual Hudson Valley Walk for Autism on Saturday April 25th from 9:00 AM to 2:00 PM at James Baird Park. He does believe this is a worthwhile thing and he would like permission for the on duty staff to go and he encourages others to attend wearing fire department T-shirts as well. He would also like to get an ambulance on standby for this event. Commissioner Kaiser suggested taking out a rig and having people on standby with that as well. Chief Champion stated that's fine as long as there are no calls. Operationally they still need to keep the district covered. He would like approval to hire back 2 for the ambulance to be dedicated to the event. Chairman Komorsky asked if anyone coming back on their own time to support this was going to be paid and Chief Champion stated no, just the two ambulance crew people. He will encourage others to attend but it is not an order.

Upon a MOTION made by Commissioner Kaiser and SECONDED by Commissioner Tierney, the Board RESOLVED to approve hiring back two staff members for overtime to man the ambulance as a dedicated vehicle, and career staff to attend for the Hudson Valley Walk for Autism on Saturday April 25th from 9:00 AM to 2:00 PM. Kaiser – Aye, Taft – Aye, Tierney – Aye, Komorsky – Aye. **Motion Carried.**

- Lexipol Policy Updates – Chief Champion said all of the policies for the LaGrange Fire District Policy Manual have been provided to the Local. His understanding is that they are in review with them. They have formed a committee to take care of it. At Monday's meeting they did approve a few policies, but he does not yet have communication back as to what policies they are. He has also asked them that they provide a written communication to the Board and the Chief staff on what policies they would like to discuss further for negotiation as well as their acceptance of any other policies by the Friday before the May 12th meeting. That way he can

BoFC Regular Meeting 4/14/26

Please note that this meeting was conducted in person at 504 Freedom Plains Road in Poughkeepsie, NY AND open for public viewing and/or listening via Microsoft Teams.



LAGRANGE FIRE DISTRICT

504 Freedom Plains Rd • Poughkeepsie, NY 12603



start rolling them out to the membership. Chairman Komorsky asked if the attorney was involved in any policies that are still not decided upon. Chief Champion stated any policy that the Union would like to discuss should involve the attorney and Chairman Komorsky as they are contractual. Chairman Komorsky asked that Chief Champion make sure the attorney has a copy. Attorney Hekle stated at this point they are waiting to hear back from the Union at this point. Chief Champion stated he has provided the attorney with the index for the policies and he can e-mail an electronic version that was provided to the Local as well.

- Operational Software Overview – Chief Champion stated that to his understanding at this time the back bills for ESO have been paid. There have been no changes to the website or any additional communication so he will be reaching out to them in the early part of next week. He does have a few questions out to their contact at First Due and he is waiting for a reply back on that. Most likely, they will set up a calendar date to have a meeting. He did ask Mr. Lenkowski to address the Board as there are some issues that he did have questions on. Chairman Komorsky stated that everything he is reading in the stock market leads him to believe that software is going away with the increase in AI. He asked if this software was going to be obsolete within the next six months or a year because of the AI aspects that are taken over everything. Mr. Lenkowski stated more than likely not in the next six months to a year. 5 to 8 years out it could be possible. Chairman Komorsky just wanted to make sure they are not throwing money at something that is going to be quickly replaced. Mr. Lenkowski stated you still need an application that will let you do the management of the fire department. They need something that will track the calls and record the calls and all of the minutia detail of each call. He does not think that is going to go away in the near or distant future. They will still need an application to do that. The applications may start to use AI to do some of that to see averages and do some predicting. The applications will be cloud based so software will have to be there in some form or fashion. Software vendors are moving away from things such as QuickBooks. Intuit has a version that is designed for on premise, but they are trying to move everyone to the cloud solution. They have marked the price up 400%. Microsoft Office is moving completely to the cloud within the next six years. Things are definitely moving towards AI, but you still need applications to run and manage and store the data. AI can help generate reports and other variants and variables. Mr. Lenkowski stated they do have an issue with the server but was told they will discuss that in executive session. It is a security issue. Blue Dragon will be here on Saturday to take care of the sound system as well as install fiber optic cabling for the drone on the roof. The reason they have to go with fiber optics is because it is outside and environmental conditions such as lightning could blow out every piece of computer equipment in the building. The fiber optics don't transmit electricity. It will be in a pipe and up to code. This will prevent damage to internal equipment. There will be a small network switch in the box on the roof. In the event that there is lightning strike and that gets damaged it will damage the drone system and the switch outside, which is inexpensive, but it will not touch any of the equipment inside. Chairman Komorsky asked if there was an issue with exposure to heat or freezing cold. Mr. Lenkowski stated it is industrial grade equipment and it can handle -40° up to 170°. He stated in regard to station 1 he sent a message up to Lieutenant Zaluski and asked him to send someone in to prop open the door because it had gotten up to 85°. Chairman Komorsky stated with having heat above what it should be already for prolonged periods of time what is the risk that there is damage being done right now. Mr. Lenkowski stated it is a very high risk to have damage to the fire alarm system, the door access control system, the

BoFC Regular Meeting 4/14/26

Please note that this meeting was conducted in person at 504 Freedom Plains Road in Poughkeepsie, NY AND open for public viewing and/or listening via Microsoft Teams.



LAGRANGE FIRE DISTRICT

504 Freedom Plains Rd • Poughkeepsie, NY 12603



network switch firewall. Commissioner Kaiser stated they were out there the other day and the one thermostat is not working correctly. His question is if air handling is cooling anything off at this point. Chairman Komorsky asked the Chief if someone could open the door and Chief Champion stated it was already done. Mr. Lenkowski stated when they were there the other day the return system was sucking air from the room into the return. Based on the current temperature he does not feel that is enough. Commissioner Kaiser stated that CPL stated it would be cool enough with just air being sucked under the door, but they all agree that is not enough. His fear is that CPL will tell the Board that it's because the air is not working properly right now. His question is if the AC system is up and working, can they go back to CPL. Chairman Komorsky asked if they went to Tractor Supply or Home Depot and bought one of the farm fans to blow air into that area would it cool anything. Mr. Lenkowski stated he believed it would circulate air, but it would circulate warm air. It would all depend on the temperature of the air that you were introducing into the room. They need something that is an enclosed rack with a condenser outside like on an AC split unit or a water unit. Chairman Komorsky stated he spoke with Mr. Lenkowski about bringing in Steve Turner or someone to put in a unit that will cool that room to at least 70° or less. That way they don't destroy the equipment that is there. He asked if anyone had any opinion on that. Commissioner Tierney stated they could do a mini split in there as well. He stated for now they can prop the door open and put a fan there to circulate the air. Commissioner Taft stated he is worried about having an issue with the split unit. He asked if they make a unit that would dehumidify. Mr. Lenkowski stated the air conditioner at Station 3 had the dehumidifier in it, but somebody turned it off. Commissioner Taft stated they need to find a way to keep that from happening again. Mr. Lenkowski stated the mechanical room is card access only. It is restricted to only the officers and chief staff. He does believe they are changing the lock tomorrow and then the commissioners will be able to get in. As long as no one messes with it, they should be OK. Chairman Komorsky stated he is just concerned about the equipment they just put in there going bad. He would like to see something done as soon as possible personally. Every time he goes out there it is hot as can be. Mr. Lenkowski stated one thing they have to remember is that the building is set to 72°. The door to that room is closed and they are relying on air coming through a three quarter inch gap under the door and then being sucked into a return that goes someplace. The temperature of the room will never be 72° because the equipment is generating heat. The temperature of the air coming in is still warmer than the maximum air temperature they want for the equipment. Chairman Komorsky stated if they put a clothes dryer in there it could kill the whole system within a matter of hours. He stated in his opinion it is not working now, and it is not going to work later. They will continue this conversation in executive session. Commissioner Tierney mentioned they used to have a parapet on the side of the building at Station 2 and now they are going to have a drone on the top of the building. He asked if there was any need for any type of lightning rod. Mr. Lenkowski suggested maybe not a lightning rod but something around the perimeter of the building. Commissioner Taft asked him if he had ever heard of a precision air pack. Mr. Lenkowski stated yes they are a computer room air conditioner. They are very expensive at around \$25,000. It would still require a roof penetration for a condenser outside. He stated he does not feel they have enough equipment in the room to warrant that. The Chairman asked Mr. Lenkowski what he would recommend putting around the building. Mr. Lenkowski stated his recommendation would be to get with the electricians. He has seen them use the perimeter of the roof having 6 or 8 inch copper spikes sent to the building ground. He does highly recommend getting with an electrician for that. Chairman Komorsky asked if it

BoFC Regular Meeting 4/14/26

Please note that this meeting was conducted in person at 504 Freedom Plains Road in Poughkeepsie, NY AND open for public viewing and/or listening via Microsoft Teams.



LAGRANGE FIRE DISTRICT

504 Freedom Plains Rd • Poughkeepsie, NY 12603



should be at both stations and Mr. Lenkowski said yes. Commissioner Kaiser will make phone calls to the lightning rod companies to see what their recommendations are. Mr. Lenkowski stated one thing to bear in mind is that there are antennas on the east side of the building and the drone antenna will be mounted as well. Those things will attract lightning. Commissioner Taft asked if they were insured for lightning strike damage and Chairman Komorsky said yes. They still would like to deter it from happening.

- Grant Update – Chief Champion stated he is hoping that by the end of the month he will have submitted all of the reimbursement requests associated with the SAFER Grant. The federal government is still shut down so there may be some delays in getting a reply back from them. In regard to the county grant he will work on getting access for Brown and Weinraub by the end of the week as long as the County is good with giving that access. Chairman Komorsky stated there is already an e-mail that has been sent to Caterpillar for getting a price on the generator. He should have it by tomorrow. Chief Champion stated once he gets a estimate from Blue Dragon on the cameras he will get all of that information to those gentlemen to work on that specific grant. They did receive the reimbursement funds from the County for the purchase of the Lucas device. It was almost \$20,000. Commissioner Tierney asked if there was a list of all the grants they are looking into and Chief Champion stated he had a list of some of the newer ones that had just come out. There are some things they are looking to do that might fit into those grants. The Board has also employed Dan Nichols to do the grant for the SCBA's. That is in process but not up and operational at this time. As soon as Mr. Nichols gives the OK they will be moving forward. They did just close one and they are looking for two more and the Deputy Chief will speak about the SCBA grant.
- Grant Writing Update – Deputy Chief Zittel stated one of the grants they are looking to is local and the other is from the federal government. As the federal government has not opened back up completely yet they are still waiting on that one. Chairman Komorsky stated there is some local things on the way and they are still open so hopefully they will find something that will apply to them. Commissioner Kaiser stated he went to the Hudson Valley Honor Flight this past Saturday. Lagrange's retired mechanic was on the flight. Everyone enjoyed it and Jack had a great day. While he was there, Commissioner Kaiser spoke to Congressman Pat Ryan. The Congressman knew they are having issues with the Town Center, and he said he would love to work with LaGrange in regard to grants and whatever else they need. Commissioner Kaiser suggested setting up a time to meet with the Board and the Congressman said that would be great. He now has the contact for the Congressman's Director of Operations. Chairman Komorsky stated those contacts are very helpful because that is how they got the last SAFER Grant with Congressman Schumer's assistance. Chairman Komorsky thanked Commissioner Kaiser for reaching out like that.
- Mechanical System Service Agreement - Chief Champion stated he has one solicitation for monitoring and upkeeping the HVAC. Given that one he did reach out to four other HVAC companies via the web. The automatic replies were yes they were interested and to please contact them. He did e-mail back the contact numbers with the scope of work that he and Commissioner Tierney and Jen Kaiser worked on. None of them got back to him. At this time he is recommending going with the quote provided by Redemption Mechanical To maintain and keep the HVAC systems up and running. He stated he would provide copies of the four emails,

BoFC Regular Meeting 4/14/26

Please note that this meeting was conducted in person at 504 Freedom Plains Road in Poughkeepsie, NY AND open for public viewing and/or listening via Microsoft Teams.



LAGRANGE FIRE DISTRICT

504 Freedom Plains Rd • Poughkeepsie, NY 12603



so it does get filed for auditing purposes. Attorney Hekle thanked him for reaching out to all of those vendors. He just wants to make sure they have something in writing to prove that there was no response from the other vendors. They will need to come up with a current start date, so it is a full year contract. Chief Champion stated they have had the vendor doing work for them in the interim for other projects so he asked if the Board would like him to ask the vendor if this could be effective immediately. Chairman Komorsky said yes and this is separate from the other work that has been done. Commissioner Kaiser suggested having it effective April 15th, 2026.

Upon a MOTION made by Commissioner Kaiser and SECONDED by Commissioner Tierney, the Board RESOLVED to approve the proposal from Redemption Mechanical on the maintenance of the mechanical systems service agreement, the AC units, the UV sanitizers, the ice machines, the air compressors, the water softeners, and the oil pressure tank with filter and softener at a total cost of \$28,415, effective April 15th, 2026, through April 15th, 2027. Kaiser – Aye, Taft – Aye, Tierney – Aye, Komorsky – Aye. **Motion Carried.**

Chairman Komorsky asked if they wanted to pay this quarterly, monthly, or one lump sum payment. His suggestion would be to pay it quarterly because there is no advantage one way or the other.

Upon a MOTION made by Commissioner Tierney and SECONDED by Commissioner Taft, the Board RESOLVED to pay Redemption Mechanical quarterly for this service agreement. Kaiser – Aye, Taft – Aye, Tierney – Aye, Komorsky – Aye. **Motion Carried.**

Chief Champion stated they had water testing at all three stations three years ago and they need to find a new company to do that. Once that comes back it may be the recommendation to install a filter and that was a preemptive inclusion in the contract so it would not have to be altered in the future. Commissioner Kaiser stated that he did believe after speaking with Steve at Redemption Mechanical that it would benefit them to filter the sediment out.

Commissioner Tierney stated he thought the new laws were that any public water had to have an ultraviolet light. Commissioner Kaiser stated there is a company across the river that can test the water, so they do have options to get that done. Chief Champion stated he believes they are the only one in the area that do that. He knows that Redemption Mechanical has done water testing in the past and he asked the Board what they would like to do. Commissioner Kaiser asked if they had to do it at all three stations. Chief Champion stated 3 years ago when he went around with Commissioner Sassi, they took samples from all three stations and brought them to the facility on Titusville Rd. That facility is no longer there. He does recommend testing the water at all three buildings. Commissioner Kaiser stated that Station 2 has town water so it should hopefully be good. Chief Champion stated he would recommend testing them at all three stations. Commissioner Kaiser asked who was in charge of maintaining the water softener at this facility. Chief Champion stated there is salt going in the softeners and the filter is getting changed in this building. It is something that he took over as Lieutenant and has continued to monitor going forward. Commissioner Kaiser stated he found Environmental LabWorks, who does testing and he believes they are the only one in the area that do it. He stated he will reach out to them. Commissioner Tierney stated he feels they should just authorize Commissioner Kaiser to have the testing done. Commissioner Kaiser stated he will text the Board what the cost will be prior to having it done. Steve Turner had

BoFC Regular Meeting 4/14/26

Please note that this meeting was conducted in person at 504 Freedom Plains Road in Poughkeepsie, NY AND open for public viewing and/or listening via Microsoft Teams.



LAGRANGE FIRE DISTRICT

504 Freedom Plains Rd • Poughkeepsie, NY 12603



recommended putting in a filter to get the sediment out. They will only need a UV light if they have E coli in the system.

- Town of LaGrange Board Meeting Update - Chairman Komorsky stated he is not for or against these agenda items, but on tomorrow night's agenda there is an application for a rezoning request from the Town in the Gateway Hamlet by Route 82 and the Taconic State Parkway to Arthursburg Rd. There is a 4.26 acre lot. It is in a low density residential area. The zoning administrator already stated that what is being proposed is an illegal usage. Tomorrow night they are on the agenda to ask the Town Board to change the law to allow them to put up one 3-story building and one 2-story building adding up to 71,300 square feet for a self-storage facility. Chairman Komorsky did speak to the Chief about this when it was initially announced and he asked the Chief if he could attend this meeting. The Chairman will be there and if anyone else from the Board would like to go they should be there as well. If it gets overturned and they change the law of the gateway hamlet he does believe they need to be there to see what direction they are going. He does feel if it gets approved they may need to consider making this a special taxing district because they do not have anything that can handle a three story building like that. He has done some due diligence. There have been quite a few fires in these type units across the country because people are storing gas cans and other flammables. There was a fire in Wappingers Falls two years ago. Commissioner Kaiser stated there are 1400 fires annually in self-storage units. Chairman Komorsky stated people store things in these units that shouldn't be and that makes them very dangerous. Commissioner Kaiser stated if this is going to be a three story building he is sure that the chief will recommend that it be sprinklered. Chairman Komorsky stated his concern is the 71,300 square feet of space on a four acre lot. It would be behind the gas station. It borders an adjacent lot in East Fishkill that they plan to put additional storage units on. Part of Chairman Komorsky's concern is that if there is a fire in those units, LaGrange would be called in to help assist at that incident as well and to protect the lot in LaGrange. Captain DeMilto stated that when there is a call at the plaza across the street, LaGrange gets called in because the alarm panel is in their district. Chairman Komorsky stated there is an aquifer on that property and on the East Fishkill property that runs through LaGrange. Chairman Komorsky stated again he is not for or against this application. He just wants to alert everyone of what is going on and make sure that they are aware. He does feel that the chief staff should be there and commissioners if they can, just to hear what is going on. He does feel it is an important issue to be aware of. Commissioner Tierney asked if there was anything on their agenda regarding batteries and Chairman Komorsky stated not as of yet. Chief Champion stated earlier this week one of the council persons did reach out to him and requested the sprinkler and standpipe codes that were provided in February to the Town Board. He did forward that to them. He was asked to address the Town Board in regard to sprinklers and standpipes so if he is asked tomorrow night he will probably have a small blurb regarding the safety factor of sprinklers per code and definitely in regard to a storage facility, given the amount of problems happening nationwide. Chairman Komorsky stated he feels the standpipe and sprinkler code is a necessity here. Commissioner Kaiser stated another town issue had to do with their inspection. When the building inspector came out he had an associate that works at the Town Hall with him. Commissioner Kaiser was shocked that when she came for the inspection she asked what the rooms were for. She had no idea that there is paid staff in the Fire Department. She had no clue what the Fire Department is all about. It is concerning to him that they live in the Town, and the Town Hall

BoFC Regular Meeting 4/14/26

Please note that this meeting was conducted in person at 504 Freedom Plains Road in Poughkeepsie, NY AND open for public viewing and/or listening via Microsoft Teams.



LAGRANGE FIRE DISTRICT

504 Freedom Plains Rd • Poughkeepsie, NY 12603



does not understand the Fire Department has career staff here 24 hours a day. He understands they can't change that, but it is very concerning. Commissioner Taft stated it is probably someone from the Planning Department. She probably doesn't live in LaGrange. She wasn't there on official business. Chairman Komorsky stated he feels that Commissioner Kaiser is trying to convey that they cannot make any assumptions that anyone in the Town understands all the aspects of how things work at the Fire District. Commissioner Kaiser stated they did go to the presentation by the Sierra Club. Chief staff was present as well. It was more of an informational meeting from the participants of the Sierra Club. They asked a lot of good questions. The Board members had good questions from the point of view of taxpayers, and the Chief Staff had good questions and comments. He does have some concerns. There was one professor from Vassar College who does not live in the Town, and their proposal was to put one of these units on Vassar's property. There was someone from the State there and they also hired a company to come and speak as well. Overall it was a lot of good information, and he believes they got a lot of good points across as well. Chairman Komorsky gave credit to Commissioner Kaiser for asking how much this is going to reduce our electric bills. The response was it will not reduce your electric bills at all. It will just slow it down from increasing as high as it could go. Chairman Komorsky had asked how much electricity from these battery storage units was going to be dedicated to people, businesses, and residents in the Town of LaGrange verses Central Hudson taking it all and selling it to the highest payer in the State and they could not answer that question. Commissioner Kaiser stated they could not answer a lot of questions. Chairman Komorsky stated there were a lot of inconsistencies and contradictions even from the Chief of Hazmat. Commissioner Kaiser stated that he spoke with the Hazmat Chief afterwards, who has been hired for this, and he does not believe that what he had to say is a great asset to this cause. Chairman Komorsky stated that everybody who is not involved in the town or the fire district believes that this will increase the electricity that they are going to get at a lower cost and that is not the case. That is the great misnomer that they have to be conscious of. Everyone thinks it is going to reduce the cost of electricity, but it won't. Commissioner Tierney stated that Central Hudson did not agree to putting one in the Town of Poughkeepsie because it is a hit to their revenue. That money would get taken away from putting up local poles and wires. Chairman Komorsky stated if he gets any updates he will pass them on as soon as he gets them. Commissioner Kaiser stated the meeting was not to not have them in Town. The Town would like to have a six month moratorium to figure out what to do.

- Building Repairs/Repair Requests – Chairman Komorsky asked if there were any other building or repair requests that have not yet been discussed. Commissioner Kaiser stated the Station 3 septic is complete. They're just waiting for the Town to blacktop for them. The manholes were lifted up with risers. In regard to Station 2 when they realized the tanker broke the lid on the manhole, they noticed there was a problem with the pipe exiting to the next catch basin and the town replaced the pipe which was totally rotted away on the bottom. He thanked the Town Highway for the doing that for them. The blacktop plants opened yesterday so once they start doing that, they will come and do Station 2 and 3 for the Fire District.

BoFC Regular Meeting 4/14/26

Please note that this meeting was conducted in person at 504 Freedom Plains Road in Poughkeepsie, NY AND open for public viewing and/or listening via Microsoft Teams.



LAGRANGE FIRE DISTRICT

504 Freedom Plains Rd • Poughkeepsie, NY 12603



NEW BUSINESS:

- Cyber liability policy renewal – Secretary Le stated this is an exact renewal from last year. The cost went up approximately \$50 otherwise there was no change to the policy. If anyone wants to see a full copy of the policy it is in the Teams file or it can be emailed directly to them.

Upon a MOTION made by Chairman Komorsky and SECONDED by Commissioner Taft, the Board RESOLVED to approve the Cyber Liability Policy renewal for a total of \$5,762.88. Kaiser – Aye, Taft – Aye, Tierney – Aye, Komorsky – Aye. **Motion Carried.**

- Station 3 siding - Chairman Komorsky stated this is the siding for the north wall. Chief Champion stated this hits the two gabled ends of the building. Chairman Komorsky stated this is the proposal from K&J Devens Inc. Construction. It is for the 2 gable ends of the north end engine bay. It is the cost of labor and materials to install aluminum drip cap on the bottom, cover holes, install Typar vapor barrier, and install double 4 white vinyl siding on both gable ends with J-channel trim At a cost of \$3,970.

Upon a MOTION made by Chairman Komorsky and SECONDED by Commissioner Tierney, the Board RESOLVED to the proposal from K&J Devens In the amount of \$3970 for the Station 3 siding repair on the north end engine bay. Kaiser – Aye, Taft – Aye, Tierney – Aye, Komorsky – Aye. **Motion Carried.**

Commissioner Kaiser stated that is the gable end on the far left bay. It is not for the right side of the whole building. Chairman Komorsky asked Secretary Le to let Devens know to move forward with this. Commissioner Tierney asked if Secretary Le could ask them about a rotting window on the front. It appears that the frame is pretty much shot. He asked if she could get an estimate from them for that repair as well.

ABSTRACT: \$440,617.03

Upon a MOTION made by Commissioner Tierney and SECONDED by Commissioner Kaiser, the Board RESOLVED to pay the bills for the end of March 2026 and beginning of April, as per the abstract for \$440,617.03. Kaiser – Aye, Taft – Aye, Tierney – Aye, Komorsky – Aye. **Motion Carried.**

Chief Champion stated he had handed out a page to the Board to look over for surplusing some IT equipment. He is looking for approval for this so it can be surplused. He will reach out to the proper IT disposal and have it taken care of. These are all desktop computers. The LD numbers associated on this page are linked to the serial numbers. Mr. Lenkowski stated the hard drives had been removed from these devices and they are in the Chief's possession. They are little chips and he suggested to the Chief to take a hammer to each one of them and smash them. There is no district data that can be leaked out.

Upon a MOTION made by Commissioner Tierney and SECONDED by Commissioner Kaiser, the Board RESOLVED to declare these desktop computers as surplus, minus the hard drives and the chips which will be destroyed and dispose of them appropriately. Kaiser – Aye, Taft – Aye, Tierney – Aye, Komorsky – Aye. **Motion Carried.**

BoFC Regular Meeting 4/14/26

Please note that this meeting was conducted in person at 504 Freedom Plains Road in Poughkeepsie, NY AND open for public viewing and/or listening via Microsoft Teams.



LAGRANGE FIRE DISTRICT

504 Freedom Plains Rd • Poughkeepsie, NY 12603



Chief Champion stated in the telephone contract it was asked what preventative maintenance covers. He reached out to the vendor, and they stated they covered the board, the phones if they go bad, it includes any labor associated with that. What it does not cover is any human act of destruction or any acts of God which would destroy the components of the phone. Chairman Komorsky thanked the Chief for getting that information.

UNION REPORT: None.

DEPARTMENT REPORT - Commissioner Kaiser stated the Department meeting will be the 21st of this month at Station 2. Notice was sent out and he only received one contact back. He will send it out again. Membership had asked that this be done quarterly and they had pushed it. They are looking at dinner at 6:30 and the meeting starting at 7 on Tuesday the 21st. Chief Champion stated the e-mail went out one week ago.

PUBLIC COMMENTS:

At 8:11PM, Chairman Komorsky opened the meeting to public comments. There was no one.

EXECUTIVE SESSION:

At 8:12 PM, upon a MOTION made by Commissioner Tierney and SECONDED by Commissioner Taft, the Board RESOLVED to go into Executive Session to discuss one contractual item, one item regarding the computer room temperature issue, one attorney discussion regarding construction at Station 1, an IT issue regarding server security from Chairman Komorsky, one item regarding Station 1 kitchen from commissioner Taft, one personnel item from Deputy Chief Merritt, two legal/contractual and three personnel items from Chief Champion, two follow up on previous staff issues, one item regarding Station 1, and one personnel issue from Commissioner Kaiser. Kaiser – Aye, Taft – Aye, Tierney – Aye, Komorsky – Aye. **Motion Carried.**

OPEN SESSION:

At 10:41 PM, the Board resumed Open Session.

Chief Champion stated they had hose testing conducted last week. The company that was here doing the hose testing caused damage to 47-13 while they were re-racking the hose. They damaged the rear rotator, which is the upper light. He does have an incident report that is being filed and he has a note from Captain DeMilto. The vendor admitted they did it and they will be coming back. Other than that the hose testing and ladder testing went well.

Upon a MOTION made by Commissioner Tierney and SECONDED by Commissioner Kaiser, the Board RESOLVED to approved spending up to \$1500 on a converter cooling unit for Station 1 to include the equipment, installation, and the venting. Deputy Chief Merritt is given permission to go purchase the unit. Kaiser – Aye, Taft – Aye, Tierney – Aye, Komorsky – Aye. **Motion Carried.**

BoFC Regular Meeting 4/14/26

Please note that this meeting was conducted in person at 504 Freedom Plains Road in Poughkeepsie, NY AND open for public viewing and/or listening via Microsoft Teams.



LAGRANGE FIRE DISTRICT
504 Freedom Plains Rd • Poughkeepsie, NY 12603



PREPARE 4/28/26 MEETING AND WORKSHOP AGENDA: Secretary Le will prepare this.

ADJOURNMENT:

At 10:45 PM, upon a MOTION made by Commissioner Tierney and SECONDED by Commissioner Taft, the Board RESOLVED to adjourn the meeting. Kaiser – Aye, Taft – Aye, Tierney – Aye, Komorsky – Aye. **Motion Carried.**

Respectfully submitted by

Julie Beyer on behalf of

Bria Le – District Secretary

Approved by the Board of Fire Commissioners on 4/28/26

BoFC Regular Meeting 4/14/26

Please note that this meeting was conducted in person at 504 Freedom Plains Road in Poughkeepsie, NY AND open for public viewing and/or listening via Microsoft Teams.

O&D Electric Corp
175 Jersey Ave
Port Jervis, NY 12771
845-691-9494

04/09/2026

Lagrange Station 1
Attn: Vince

Re: Parking Lot Lights

Thank you for the opportunity to bid on the above-mentioned project. Our pricing is as follows:

1. Remove existing utility pole.
2. Set underground box, hand trench to building, tie into existing underground wiring.
3. Install new photocell and time clock.
4. Install new circuit breaker.
5. Retro fit existing light pole head to LED.

PRICE = \$12,000.00

If you have any questions or additional information is needed, please contact our office. Thank you again for your consideration.

Respectfully,

Matthew Canale
President

WORK CHANGE DIRECTIVE NO. 5

Owner: LaGrange Fire District
Engineer: M.J. Engineering, Architecture, Landscape Architecture and Land Surveying, P.C.
Contractor: JC Land & Site Development Inc.
Project: LaGrange Fire Station No 2
Contract Name: LaGrange Fire Station No 2 Site Improvements
Date Issued: April 2, 2026 Effective Date of Work Change Directive: April 2, 2026
Owner's Project No.:
Engineer's Project No.: 1878.01
Contractor's Project No.:

Contractor is directed to proceed promptly with the following change(s):

Description: **Contractor to sawcut asphalt apron at east entrance. Contractor to transport and spread two trucks of item 4 at top entrance to level out the settled area between training area and asphalt apron.**

Purpose for the Work Change Directive: **District would like repair settlement at east entrance asphalt apron.**

Directive to proceed promptly with the Work described herein, prior to agreeing to change in Contract Price and Contract Time, is issued due to:

Non-agreement on pricing of proposed change. Necessity to proceed for schedule or other reasons.

Estimated Change in Contract Price and Contract Times (non-binding, preliminary):

Contract Price: \$3,500 [increase]

Contract Time: 0 days

Basis of estimated change in Contract Price:

Lump Sum Unit Price Cost of the Work Other

Recommended by Engineer

Authorized by Owner

By: 

Title: Senior Engineer

Date: April 2, 2026

WORK CHANGE DIRECTIVE NO. 7

Owner: LaGrange Fire District
Engineer: M.J. Engineering, Architecture, Landscape Architecture and Land Surveying, P.C.
Contractor: JC Land & Site Development Inc.
Project: LaGrange Fire Station No 2
Contract Name: LaGrange Fire Station No 2 Site Improvements
Date Issued: April 2, 2026 Effective Date of Work Change Directive: April 2, 2026
Owner's Project No.:
Engineer's Project No.: 1878.01
Contractor's Project No.:

Contractor is directed to proceed promptly with the following change(s):

Description: **Contractor to replace three 6-foot white pines with three 6-foot blue point junipers. Relocate the location of trees as shown on plan C-120.**

Attachment: **Revised C-120**

Purpose for the Work Change Directive: **District preference.**

Directive to proceed promptly with the Work described herein, prior to agreeing to change in Contract Price and Contract Time, is issued due to:

Non-agreement on pricing of proposed change. Necessity to proceed for schedule or other reasons.

Estimated Change in Contract Price and Contract Times (non-binding, preliminary):

Contract Price: **\$600** [increase]

Contract Time: **0** days

Basis of estimated change in Contract Price:

Lump Sum Unit Price Cost of the Work Other

	Recommended by Engineer	Authorized by Owner
By:		
Title:	Senior Engineer	
Date:	April 2, 2026	

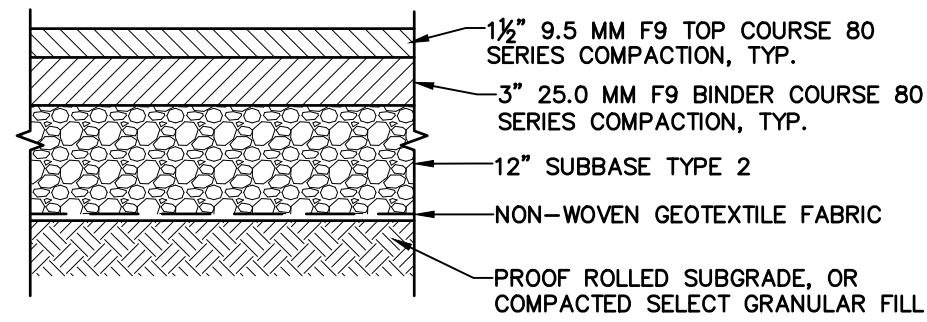

NOTES:

1. APPLY TACK COAT BETWEEN ALL PAVEMENT LIFTS PRIOR TO PLACING MIXTURE REGARDLESS OF TIME PERIOD BETWEEN LIFTS PER NYS DOT 404-3.
2. PROVIDE FILL MATERIAL, WHERE NECESSARY FOR BRINGING THE SUBGRADE ELEVATION TO A SPECIFIED GRADE, IN ACCORDANCE WITH SECTION 203 - EXCAVATION AND EMBANKMENT, OF THE ABOVE REFERENCED NYS DOT STANDARD SPECIFICATIONS.
3. REFER TO SPECIFICATION SECTION 321216 FOR PAVEMENT MATERIAL REQUIREMENTS.

1 ASPHALT PAVEMENT SECTION

SCALE: NTS

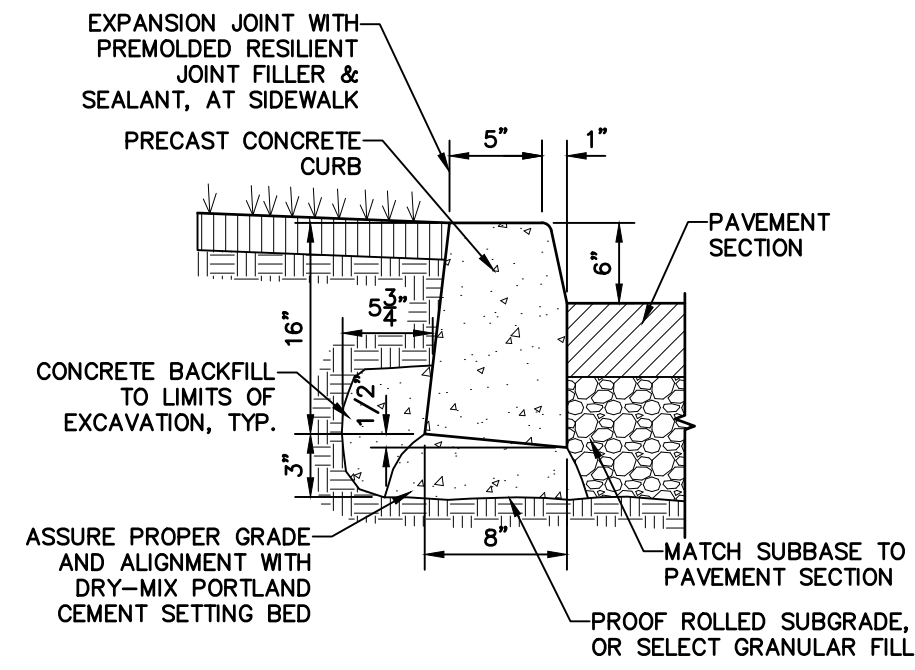

NOTES:

1. INSTALL PRECAST CURB BETWEEN ASPHALT AND ABSORPTION BED AS SHOWN ON PLANS TO PREVENT PARKING AREA STORMWATER FROM ENTERING ABSORPTION BED.
2. SAW CUT EXISTING PAVEMENT TO CREATE STRAIGHT EDGE.
3. INSTALL PRECAST CURB IN ACCORDANCE WITH MANUFACTURE'S INSTRUCTIONS.
4. SEAL JOINTS BETWEEN CURB SECTIONS TO PREVENT WATER INFILTRATION.

4 PRECAST CONCRETE CURB

SCALE: NTS

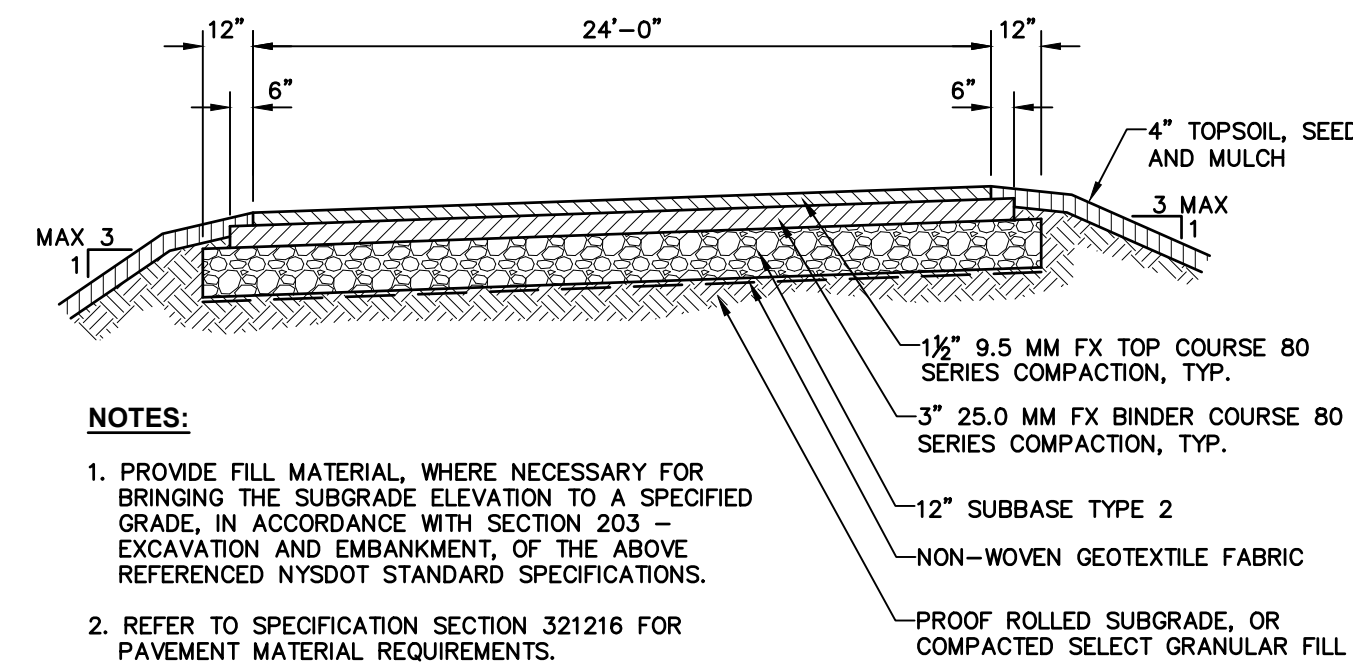

NOTES:

1. PROVIDE FILL MATERIAL, WHERE NECESSARY FOR BRINGING THE SUBGRADE ELEVATION TO A SPECIFIED GRADE, IN ACCORDANCE WITH SECTION 203 - EXCAVATION AND EMBANKMENT, OF THE ABOVE REFERENCED NYS DOT STANDARD SPECIFICATIONS.
2. REFER TO SPECIFICATION SECTION 321216 FOR PAVEMENT MATERIAL REQUIREMENTS.

7 ACCESS ROAD SECTION

SCALE: NTS

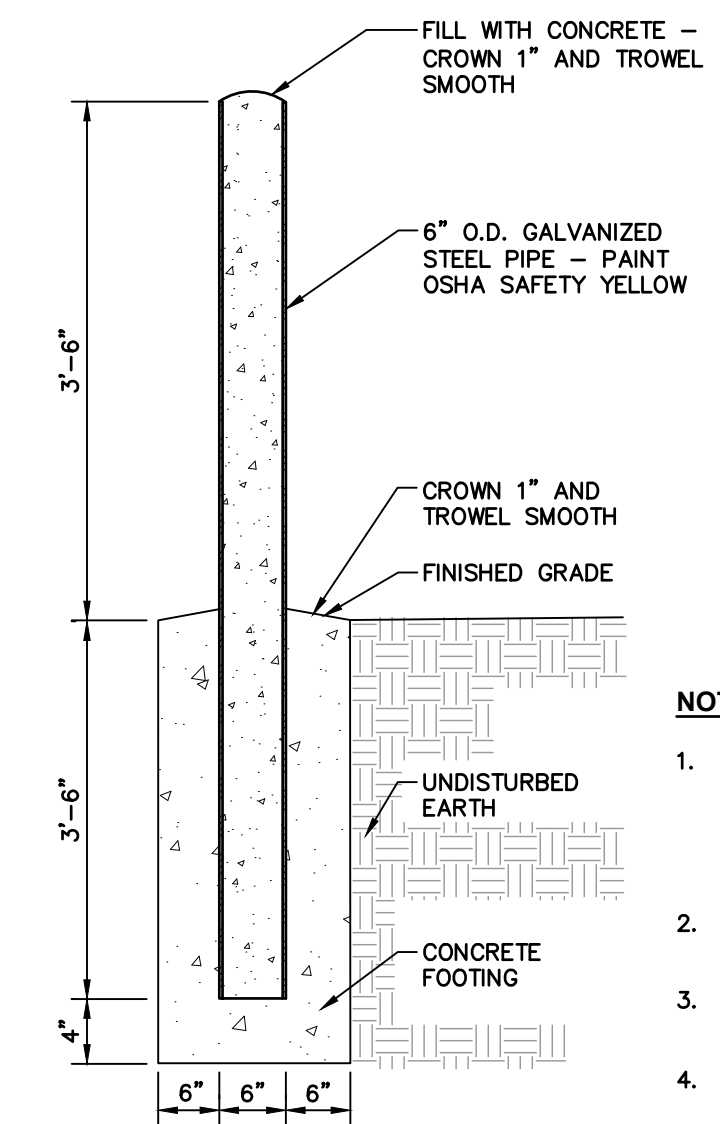

NOTES:

1. BOLLARD FINISH:
 - a. PREPARE GALVANIZED COATING TO RECEIVE PAINT.
 - b. FINISH. APPLY (1) COAT OF RUST INHIBITOR PRIMER.
 - c. APPLY (2) COATS OF GLOSS ENAMEL (COLOR SELECTED BY THE OWNER.)
2. PROVIDE CONCRETE WITH A MINIMUM COMPRESSIVE STRENGTH OF 3,000 PSI @ 28 DAYS.
3. PROVIDE CONCRETE WITH A SLUMP OF NO GREATER THAN 4" (WITH A TOLERANCE OF 1").
4. PROVIDE CONCRETE WITH A 5% ENTRAINED AIR (TOLERANCE OF 1%) CONFORMING TO ASTM C260.

10 STEEL BOLLARD (CONCRETE FILLED)

SCALE: NTS

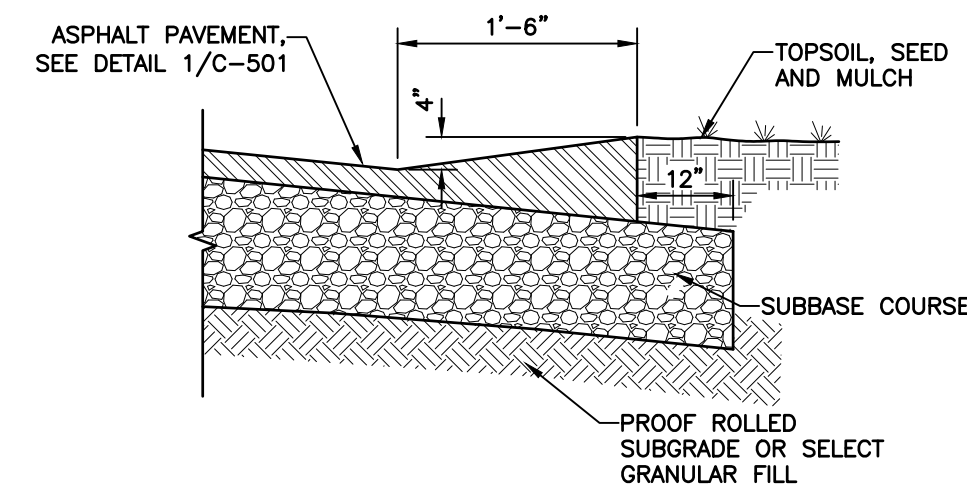

2 ASPHALT WING GUTTER

SCALE: NTS

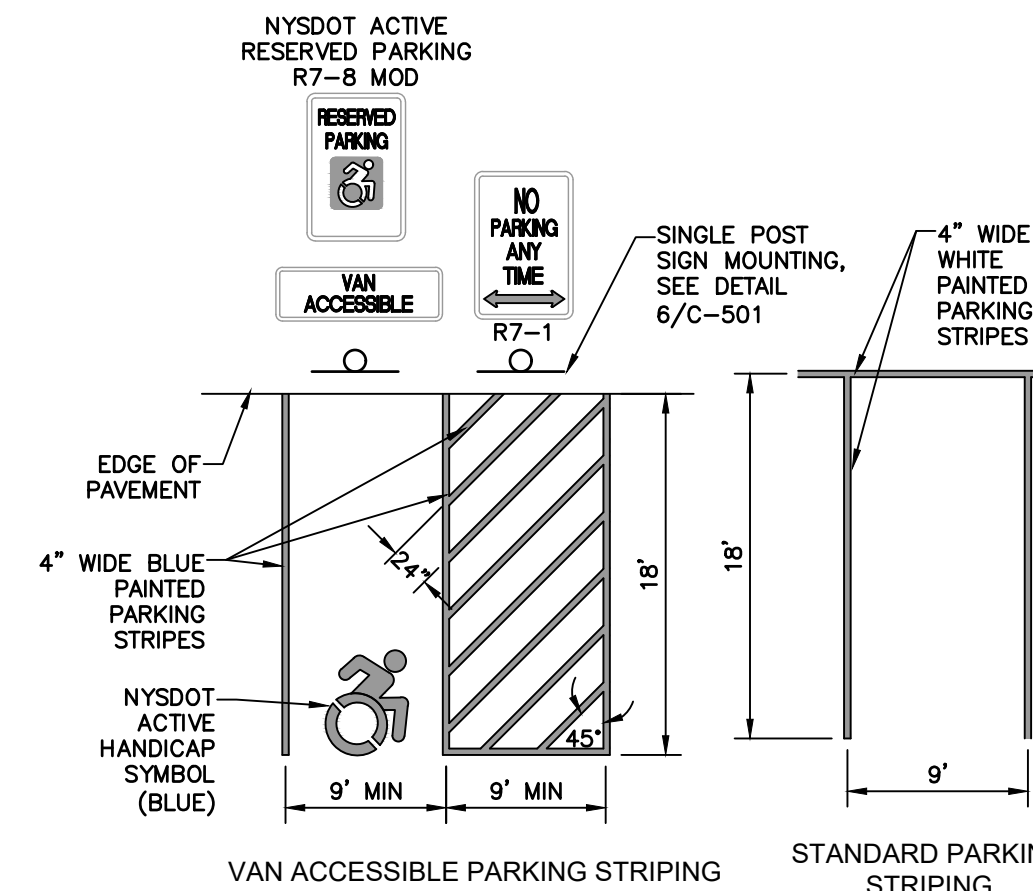

NOTES:

1. PROVIDE DIMENSIONS IN ACCORDANCE WITH ADAAG 2010 SUPPLEMENTED BY THE 2020 BUILDING CODE OF NEW YORK STATE.
2. DO NOT EXCEED 1.5% SLOPE IN ANY DIRECTION OF PAVEMENT SURFACE IN THE ACCESSIBLE SPACE AND ACCESSIBLE AISLE.
3. REFER TO SPECIFICATION SECTION 321723 "PAVEMENT MARKINGS" FOR PAVEMENT MARKING REQUIREMENTS.

8 PARKING STALL STRIPING

SCALE: NTS

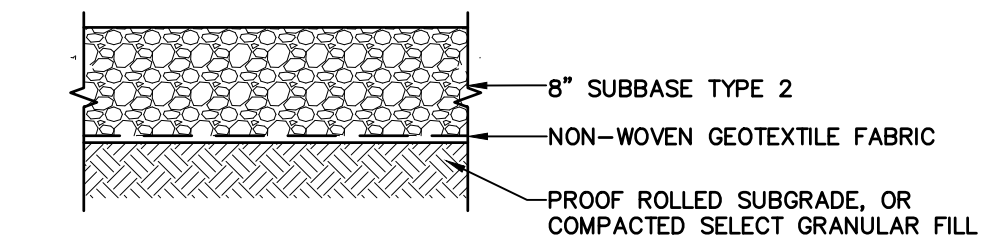

11 STORAGE CONTAINER PAD

SCALE: NTS

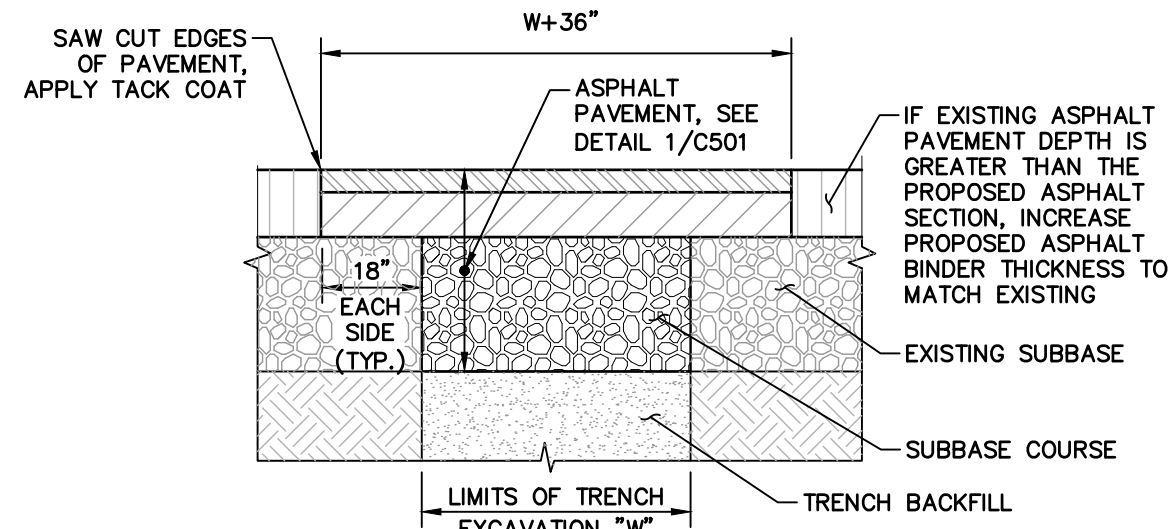

NOTES:

1. SAW CUT AS INDICATED, 18" BEYOND EXCAVATION.
2. FURNISH, PLACE AND COMPACT SURFACE.
3. TACK COAT IN ACCORDANCE WITH NYS DOT STANDARD SPECIFICATION.
4. FURNISH AND PLACE ASPHALT CONCRETE PAVEMENT AS SPECIFIED.

3 TRENCH SURFACE RESTORATION IN ASPHALT PAVEMENT

SCALE: NTS

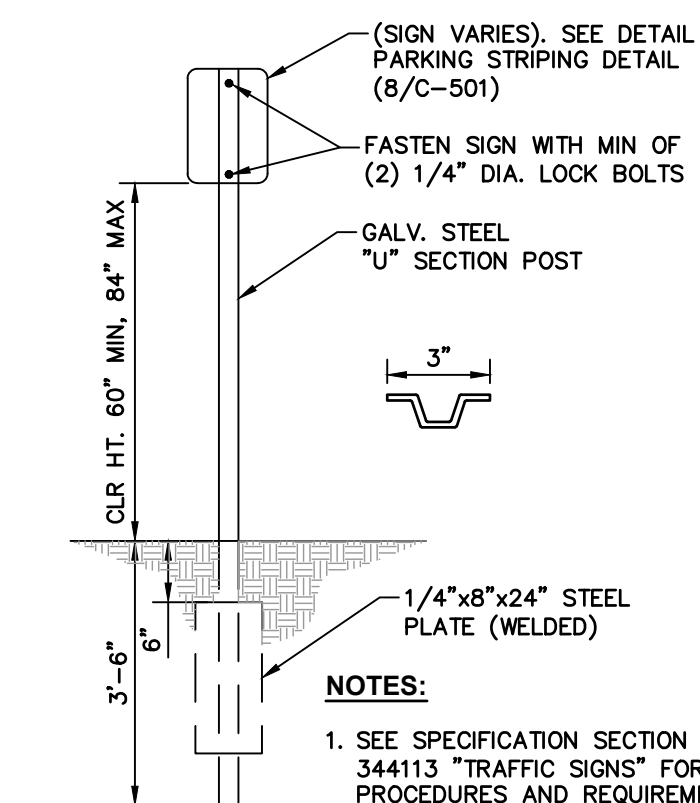

NOTES:

1. SEE SPECIFICATION SECTION 344113 "TRAFFIC SIGNS" FOR PROCEDURES AND REQUIREMENTS.

6 SINGLE POST SIGN MOUNTING

SCALE: NTS

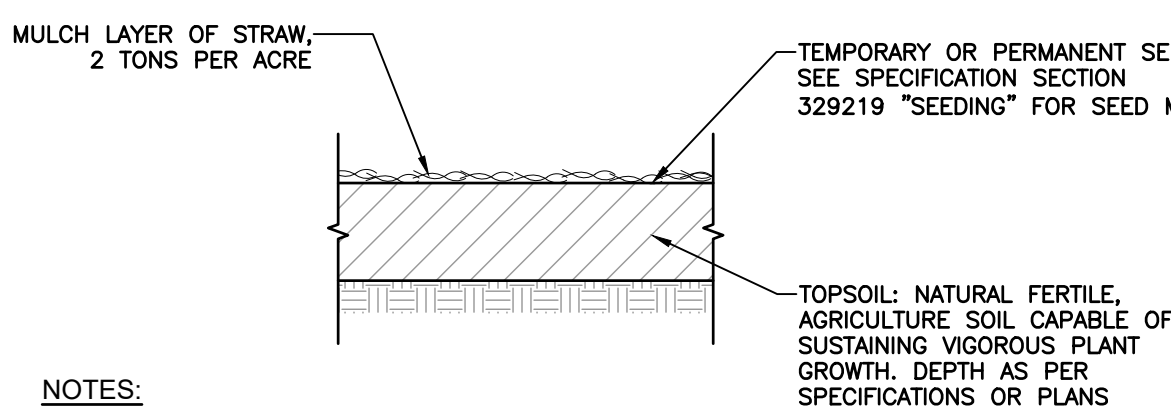

NOTES:

1. SEE SPECIFICATION SECTIONS WITHIN SECTION 329000 "PLANTING" FOR SEED PLANTING AND MULCH REQUIREMENTS AND PROCEDURES.

9 TOPSOIL, SEED AND MULCH

SCALE: NTS

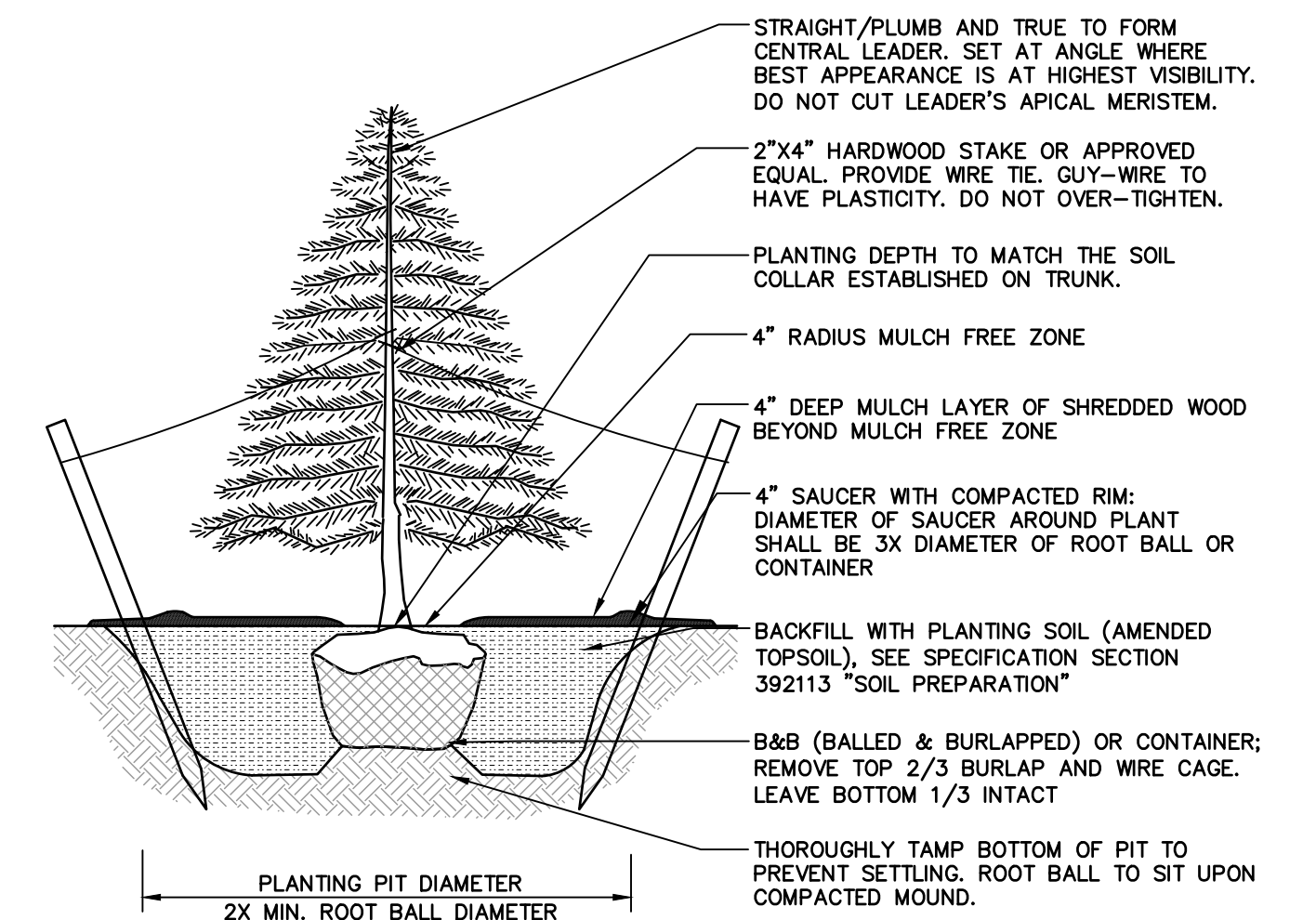

NOTES:

1. EACH TREE TO BE PROVIDED ONE 20 GALLON TREE WATERING BAG UPON PLANTING. WATERING BAG TO BE STAKED, RE-FILLED WEEKLY, AND MAINTAINED DURING THE FIRST YEAR BETWEEN MAY-OCT.
2. SEE SPECIFICATION SECTION 329300 "PLANTS" FOR PLANTING REQUIREMENTS.
3. PROVIDE WHITE PINE, B&B, 6' HEIGHT, 15' O.C.

12 TREE PLANTING

SCALE: NTS

SUBMITTAL / REVISIONS						
No.	DATE	DESCRIPTION	BY	REVIEWED BY:	DATE	
1	12/12/25	BID DOCUMENTS				

PROJ. MANAGER:	JMB
DESIGNED BY:	DMH
DRAWN BY:	DAG
CHECKED BY:	WL



THE ALTERATION OF THIS MATERIAL IN ANY WAY, UNLESS DONE UNDER THE DIRECTION OF A COMPARABLE PROFESSIONAL, (I.E.) ARCHITECT FOR AN ARCHITECT, ENGINEER FOR AN ENGINEER OR LANDSCAPE ARCHITECT FOR A LANDSCAPE ARCHITECT, IS A VIOLATION OF THE NEW YORK STATE EDUCATION LAW AND/OR REGULATIONS AND IS A CLASS "A" MISDEMEANOR.



LAGRANGE FIRE DISTRICT STATION NO. 2
SITE IMPROVEMENTS

DETAILS

504 FREEDOM PLAINS ROAD
POUGHKEEPSIE, NEW YORK 12603

SCALE: NONE
MJ PROJ. No.: 1878.01
DATE: 9/30/25
C-501



PROPOSAL

DATE: February 3, 2026

TO: Marc Komorski apogee60@yahoo.com
Bria Le secretary@lagrangefireny.us
Anthony Champion achampion@lagrangefireny.us
Robert Taft rtaft@lagrangefireny.us
Vincent Tierney vtierney@lagrangefireny.us
Jeff Kaiser jeffkaiser22@gmail.com

FROM: REDEMPTION MECHANICAL, INC
P.O. Box 50
LaGrangeville, NY 12540
STEPHEN TURNER (PRESIDENT)
845-531-9332 RMI316@OUTLOOK.COM

RE: Mechanical Systems Service Agreement (includes equipment updates to Station 2. Equipment updates to station 1 will be made when construction is complete and final walkthrough is done)
Updated agreement also includes preventative maintenance of plumbing systems in all building to include water filter changes and inclusive service calls. As well as air compressor services at all buildings as requested by Capitan DeMILto and Commissioner Kaiser

SCOPE OF WORK: Perform full service and tuning of all heating, air conditioning and hot water systems at all stations.

Station 1: 2 Oil fired hot water boilers,
1 oil fired water heater
3 Split AC systems
3 UV sanitizers
1 ice machine

- 1 air compressor
- 1 well pressure tank and water filter with softener

Station 2: 2 Natural gas hot water boilers (condensing high efficiency)

- 2 Gas roof top with AC
- 2 AC only roof top
- 1 single zone ductless heat pump
- 1-3 head ductless heat pump
- 1 gas water heater
- 5 UV Sanitizers
- 1 Ice machine
- 1 water filter with softener
- 1 air compressor

Station 3: 1 Oil fired hot water boiler with indirect water heater

- 3 split AC systems
- 1 ice machine
- 1 single zone ductless air conditioner
- 1 well pressure tank with filter and softener
- 1 air compressor

Service shall include a full inspection. Brush and vacuum of heat exchangers as necessary, oil filters and nozzles, test and adjustment of all firing rates and combustion analysis with tuning to optimize efficiency. Test and adjustment to boiler feed water systems. Purge of all hydronic zones. Testing and inspection of all electrical components and controls associated with HVAC systems. Testing of all blowers, motors, circulators and dampers. Test and adjust all safeties, limits and set points. Flush of water heaters and service as necessary. Check all refrigerant levels temperatures and pressures (does not include refrigerant). Full cleaning of indoor and outdoor AC coils as necessary. Check and cleaning of all condensate drain lines and pumps. UV sanitizer service shall include cleaning and inspection of operation as well and new elements (2 year intervals as required per manufacturer and are due). Filter changes on all units once every 2 months (filters included). Ice machine service shall be a general inspection and cleaning of all units, flushing of lines and changing of filters (filters included)

MISCELLANEOUS: Agreement shall be for a 1 year (12 month) period and shall include 2 visits on each unit for preventative maintenance and servicing as described. There will be no additional charges for service calls or after hours or emergencies. This agreement does not include any additional parts or labor beyond described in scope of work. All additional parts and labor shall include a 10% discount. Any questionable items shall be noted in a report after servicing with recommended repairs if any are found. This agreement shall also be automatically renewable every 12 months for up to 5 additional years. Total cost upon renewal may vary due to operational costs such as fuel, materials and labor but shall not exceed a 10% yearly increase.

TOTAL COST: \$28,415.00

PAYMENT TERMS: Billable monthly or quarterly whichever the board/district prefers.

Tentative start date 2/15/2026

PROPOSAL

K & J DEVENS, INC. CONSTRUCTION

545 Salt Point Turnpike
Poughkeepsie, NY 12601
Joe (914) 474.8725
KNJDVNS.INC@aol.com



To: LaGrange Fire District
504 Freedom Plains Road
Poughkeepsie, NY 12603

Phone: 845.462.4999

Date: 4/1/2026

Architect:

Job Name: North Engine Bay Siding

Job Location: Station #3

Date of Plans:

We hereby submit specifications and estimates for:

Re: Station #3 Siding on the two gable ends of the north end engine bay.

To cover the cost of labor & material to complete the following work:

- Install aluminum drip cap on bottom
- Cover holes
- Install Typar vapor barrier
- Install double 4 white vinyl siding on both gable ends with J- channel trim

We, K & J Devens, Inc. the General Contractor, are fully insured and guarantee all work to be performed in a professional manner and workmanship.

We Propose hereby to furnish labor and material complete in accordance with the above specifications for the sum of: Three Thousand Nine Hundred Seventy Dollars (\$ 3,970.00)

Payment will be made as follows: Payment in full on completion of work described above .

All material is guaranteed to be as specified. All work to be completed in a workmanlike manner according to standard practices. Any alteration or deviation from above specifications involving extra costs will be executed only upon written orders and will become an extra charge over and above the estimate. All agreements contingent upon strikes, accidents or delays beyond our control. Owner to carry fire, tornado and other necessary insurance. Our workers are fully covered by Workman's Compensation Insurance.

Note: This proposal may be withdrawn if not accepted within 30 (thirty) days.

Authorized Signature:  Date: 4/1/26

Acceptance of Proposal – The above price, specifications and conditions are satisfactory and are hereby accepted. You are authorized to do the work as specified.

Signature: _____

Signature: _____

Payment will be made as outlined above.

Date of Acceptance: _____



NOTICE OF EXCESS LINE PLACEMENT

Date: 3/31/2026

LaGrange Fire District
504 Freedom Plains Road, Poughkeepsie, NY 12603

Consistent with the requirements of the New York Insurance Law and Regulation 41, LaGrange Fire District is hereby advised that all or a portion of the required coverages have been placed by NFP Property & Casualty Services, Inc. with insurers not authorized to do an insurance business in New York and which are not subject to supervision by this State. Placements with unauthorized insurers can only be made under one of the following circumstances:

- a) A diligent effort was first made to place the required insurance with companies authorized in New York to write coverages of the kind requested; or
- b) NO diligent effort was required because i) the coverage qualifies as an "Export List" risk, or ii) the insured qualifies as an "Exempt Commercial Purchaser."

Policies issued by such unauthorized insurers may not be subject to all of the regulations of the Superintendent of Financial Services pertaining to policy forms. In the event of insolvency of the unauthorized insurers, losses will not be covered by any New York State security fund.

TOTAL COST FORM (NON TAX ALLOCATED PREMIUM TRANSACTION)

In consideration of your placing my insurance as described in the policy referenced below, I agree to pay the total cost below which includes all premiums, inspection charges⁽¹⁾ and a service fee that includes taxes, stamping fees, and (if indicated) a fee⁽¹⁾ for compensation in addition to commissions received, and other expenses⁽¹⁾.

I further understand and agree that all fees, inspection charges and other expenses denoted by⁽¹⁾ are fully earned from the inception date of the policy and are non-refundable regardless of whether said policy is cancelled. Any policy changes which generate additional premium are subject to additional tax and stamping fee charges.

Re: Policy No. ESO0340758042 Insurer: Lloyds Syndicate 1988 (Asta Managing Agency Limited)

Policy Premium	\$	5,115.00
<u>Insurer Imposed Charges:</u>		
Policy Fees ⁽¹⁾	\$	295.00
Inspection Fees ⁽¹⁾	\$	0.00
Total Taxable Charges	\$	5,410.00
<u>Service Fee Charges:</u>		
Excess Line Tax (3.60%)	\$	194.76
Stamping Fee	\$	8.12
Broker Fee ⁽¹⁾	\$	150.00
Inspection Fee ⁽¹⁾	\$	
Other Expenses (specify)	\$	
Total Policy Cost	\$	5,762.88

(Signature of Insured)

(Date)

⁽¹⁾ = Fully earned

VENDOR	Amount Due	PO #	4/14/2026
10-75 EMERGENCY VEHICLES ✓	\$ ✓48,400.00	14312	SECOND DEPOSIT ON 2026 COMMAND PICKUP
AMAZON ✓	\$ ✓459.44	15280	CLEANING SUPPLIES
BOTTINI FUEL ✓	\$ ✓3,544.92	15261	STATION 2 DIESEL FUEL
BROWN & WEINRAUB ✓	\$ ✓5,000.00	15282	PROFESSIONAL SERVICES-LOBBYIST
CASSONE LEASING ✓	\$ ✓1,998.00	15308	STATION 1 TRAILER
CHRIS BRINSON ✓	\$ ✓360.00	VCHER	MEALS REIMBURSEMENT FOR FDIC CONF 4/21-4/25
CPL ARCHITECTS ✓	\$ ✓6,318.46	15328	STAT 1 RENOVATION-ARCHITECT WORK
CRYO WELD ✓	\$ ✓37.51	15288	EMS SUPPLIES
DR. FELICE ✓	\$ ✓1,250.00	15274	EMS PROFESSIONAL SERVICES
DUTCHESS COMMUNITY COLLEGE ✓	\$ ✓400.00	5730	PALS/ACLS REFRESHERS
DUTCHESS COMMUNITY COLLEGE ✓	\$ ✓480.00	5732	AHA TRAINING CENTER AUDIT
DUTCHESS COUNTY EMS COUNCIL ✓	\$ ✓150.00	15275	MEMBERSHIP DUES 2026
EMERGENCY VEHICLE SPECIALIST (EVS) ✓	\$ ✓4,836.06	15264	VEHICLE REPAIRS
FIREHOUSE FABRICATORS ✓	\$ ✓3,090.00	15032	TRAINING PROPS FIRE
FREIHOFFER SPRINGWATER ✓	\$ ✓190.65	2026BL	WATER DELIVERY
FRONTIER ✓	\$ ✓178.84	15283	STAT 1 LOCAL & LONG DISTANCE SVD
GRAINGER ✓	\$ ✓217.32	15276	CLEANING SUPPLIES
H.G. PAGE ✓	\$ ✓43.98	5713	BATTERIES FOR EMS EQUIP
H.G. PAGE ✓	\$ ✓117.40	5716	TRAINING BUILDING SUPPLIES
H.O. PENN ✓	\$ ✓6,842.29	15265	REPAIRS TO 47-31
H.O. PENN ✓	\$ ✓4,337.20	15333	REPAIRS TO 47-
HAUN WELDING ✓	\$ ✓9.13	15272	EMS SUPPLIES
JC LAND & SITE DEVELOPMENT ✓	\$ ✓87,201.54	15336	STATION 2 SEPTIC REPLCMNT INV #1
JULIE BEYER ✓	\$ ✓210.00	2026BLE	OFFICE WORK TRANSCRIPTION
M&O SANITATION ✓	\$ ✓1,800.00	15262	STATION 2 SEPTIC PUMP
MASSMUTUAL ✓	\$ ✓573.00	15305	CAREER LIFE INS PREM
MASSMUTUAL ✓	\$ ✓380.50	15329	CAREER LIFE INS PREM
MEDICAL WAREHOUSE ✓	\$ ✓649.99	2026-SM	EMS SUPPLIES
MES SERVICE CO ✓	\$ ✓293.43	15270	GAS
MES SERVICE CO ✓	\$ ✓156.00	15248	AA BATTERIES
MES SERVICE CO ✓	\$ ✓365.00	15307	FIRE EQUIP QUARTERLY AIR SAMPLE/CALIBRATION
MES SERVICE CO ✓	\$ ✓103.99	15312	SMALL ENGINE FUEL PREMIX
MES SERVICE CO ✓	\$ ✓912.43	15310	SCBA TESTING
MES SERVICE CO ✓	\$ ✓178.29	5703	TURNOUT GEAR WASH
MES SERVICE CO ✓	\$ ✓528.44	5702	FIRE SUPPLIES
MES SERVICE CO ✓	\$ ✓1,054.00	15291	UNIFORM-BADGES
MES SERVICE CO ✓	\$ ✓498.00	15189	UNIFORM-CHIEF STAFF
MES SERVICE CO ✓	\$ ✓5,155.00	15094	UNIFORM-CAREER
MES SERVICE CO ✓	\$ ✓263.01	15306	UNIFORM-BADGES
MJ ENGINEERING ✓	\$ ✓1,577.00	15286	STAT 2 SEPTIC REPLACEMENT
MJ ENGINEERING ✓	\$ ✓12,000.00	15096	STAT 1 PHASE 2
MJ ENGINEERING ✓	\$ ✓14,025.00	15338	STAT 2 EMERGENCY GENERATOR
NYCOMCO ✓	\$ ✓130.00	15292	REPEATER CHECK
NYS HEALTH INS NYSHIP ✓	\$ ✓147,723.03	15279	EMPLOYEE HEALTH INSURANCE
O'REILLY AUTOMOTIVE ✓	\$ ✓2.50	15284	47-73 PARTS
OPTIMUM ✓	\$ ✓245.68	15320	STAT 3 CABLE/INTERNET SVC
OPTIMUM ✓	\$ ✓360.86	15319	STAT 1 CABLE/INTERNET SVC
OPTIMUM ✓	\$ ✓118.41	15318	STAT 2 CABLE SVC
QUILL LLC ✓	\$ ✓50.96	15277	CLEANING SUPPLIES
RBT CPAs ✓	\$ ✓7,161.78	15311	2022 AUDIT
REDEMPTION MECHANICAL ✓	\$ ✓2,000.00	15271	STATION 3 PLUMBING REPAIR/MAINT
REDEMPTION MECHANICAL ✓	\$ ✓6,925.00	15162	STATION 1 & 2 PRESSURE WASHER INSTALL
REDEMPTION MECHANICAL ✓	\$ ✓10,800.00	15273	STATION 3 SEPTIC REPAIR
RINGSQUARED/ACCESS PLUS ✓	\$ ✓910.67	15281	LOCAL/LONG DIST SVC STATS 2 & 3
S&O CONSTRUCTION ✓	\$ ✓38,904.40	15263	STATION 1 RENOV PLUMBING
SARJO INDUSTRIES ✓	\$ ✓376.15	15313	PARTS FOR UTV
SARJO INDUSTRIES ✓	\$ ✓114.88	205.04	SHOP SUPPLIES
SHELTERPOINT LIFE ✓	\$ ✓198.55	15334	CHIEF STAFF VISION BENEFITS
STERICYCLE INC ✓	\$ ✓131.00	15251	EMS MEDICAL WASTE SUBSCRIPTION
STRYKER ✓	\$ ✓468.19	15290	EMS SUPPLIES
TOTAL SUBMITTED (from pg 2)	\$	440,617.03	440,526.27

